

# **HAGUE** **WATERMAX®**

## REVERSE OSMOSIS APPLIANCE



### OWNER'S MANUAL AND INSTALLATION GUIDE

MODELS H2000, H2500, H3000, H3500, LC30,  
LC50, LC100, LC50P, LC100P

VERSION 4.1

## 25 Year Limited Warranty

To place the equipment under warranty, the warranty registration card must be completed and returned by the original owner to the warrantor, Hague Quality Water International, within 30 days of installation. 4343 South Hamilton Road. Groveport, OH 43125.

### Coverage

This warranty covers specified parts of the Hague WaterMax® Reverse Osmosis Appliance delivered to the original owner when the appliance is purchased for personal, family or household use from an independent Hague dealer. Appliances installed in commercial establishments will only qualify for the Commercial Three Year Limited Warranty; please refer to form #F0105. It is intended to cover defects in workmanship or materials or both.

### Warrantor's Performance and Length of Warranty

Hague Quality Water International warrants that upon receipt from the owner of any Hague RO dispensing spigot, filter housing and cap, PCF filter housing and cap, membrane housing and cap found to be defective in material or workmanship, Hague will repair or replace the defective item, at no charge for that item, for 25 YEARS from date of installation.

Hague Quality Water International further warrants that upon receipt from the owner of the RO storage tank which is found to be defective in material or workmanship, Hague will repair or replace the defective item, at no charge, for 5 YEARS from date of installation. If the permeate pump and/or auto shut-off valve are found to be defective in material or workmanship, Hague will repair or replace the defective parts at no charge, for those parts for 2 YEARS from date of installation. The membrane is covered at 100% for the first year, then prorated from the beginning of the second year through the end of the third year at 49%, plus 1-½% of the then current list price for each month the membrane has been in service. Filters are not warranted.

Should a defect or malfunction occur, contact your dealer. If you are unable to contact your dealer, then contact Hague Quality Water International.

All defective parts must be returned, along with the equipment serial number and date of original installation, to an authorized Hague dealer or Hague Quality Water International PREPAID, and replacement parts will be returned by Hague FREIGHT COLLECT.

### Further Exclusions and Limitations on Warranty:

This warranty is null and void unless the Hague Appliance was purchased from an independent Hague dealer.

### THERE ARE NO WARRANTIES OTHER THAN THOSE DESCRIBED IN THIS WARRANTY INSTRUMENT.

This warranty does not cover any service call or labor costs incurred with respect to the removal and replacement of any defective part or parts. Hague Quality Water International will not be liable for, nor will it pay service call or labor charges incurred or expended with respect to this warranty.

In the event the water supply being processed through this product contains bacterial iron, algae, sulphur, tannins, organic matter or other unusual substances, then unless the appliance is represented as being capable of handling these substances in the appliance specifications, other special treatment of the water supply must be used to remove these substances before they enter this product. Otherwise, Hague Quality Water International shall have no obligations under this warranty.

This warranty does not cover damage to a part or parts of the appliance from causes such as fire, accidents, freezing, or unreasonable use, abuse or neglect by the owner.

This warranty does not cover damage to a part or parts of the appliance resulting from improper installation. All plumbing and electrical connections should be made in accordance with all local codes and the installation instructions provided with the appliance. The warranty does not cover damage resulting from use with inadequate or defective plumbing; inadequate or defective water supply or pressure; inadequate or defective house wiring; improper voltage, electrical service, or electrical connections; or violation of applicable building, plumbing, or electrical codes, laws, ordinances or regulations.

### THIS WARRANTY DOES NOT COVER INCIDENTAL, CONSEQUENTIAL OR SECONDARY DAMAGES. ANY IMPLIED WARRANTIES ON THE PRODUCT DESCRIBED IN THIS WARRANTY WILL NOT BE EFFECTIVE AFTER THE EXPIRATION OF THIS WARRANTY.

No dealer, agent, representative or other person is authorized to extend or expand this limited warranty.

Some states do not allow limitations on how long an implied warranty lasts or the exclusion or limitation of incidental or consequential damages, so the above limitations and exclusion may not apply to you. This warranty gives you specific legal rights and you may also have other rights which vary from state to state.



# Contents

---

|  |           |
|--|-----------|
| <b>OWNER INFORMATION.....</b>                                  | <b>4</b>  |
| General Information .....                                      | 4         |
| Service Log .....  | 5         |
| Introduction to Reverse Osmosis .....                          | 6         |
| How Your Appliance Works.....                                  | 8         |
| NSF–Performance Data Sheet.....                                | 10        |
| Fact Section for Pentavalent Arsenic Treatment Appliances..... | 12        |
| <b>INSTALLATION AND MAINTENANCE INFORMATION .....</b>          | <b>13</b> |
| Checklist Before Installation .....                            | 13        |
| Installation Tool List .....                                   | 14        |
| Installation Diagram .....                                     | 15        |
| Typical Flow Diagram.....                                      | 16        |
| Booster Pump Retrofit Diagrams.....                            | 17        |
| Installation Steps and Start-Up Procedures .....               | 18        |
| Changing Filters.....  | 24        |
| Sanitizing the WaterMax® RO Appliance.....                     | 27        |
| Assembly and Parts .....                                       | 29        |
| Optional Parts .....   | 40        |
| Troubleshooting .....  | 41        |
| RO Specifications.....   | 43        |
| Certificates .....   | 44        |



## General Information

*Congratulations* on choosing a superior Hague water treatment appliance! Use this guide to attain the maximum benefit from your appliance. As an owner, you may find the first few pages to be the most helpful in solving your needs. If you have trouble with the operation of your appliance, see *Troubleshooting* in the back of this manual or contact your independent Hague dealer.

Completely fill out the Warranty Card and return it by mail to ensure that the appliance is registered with the factory and the warranty becomes validated.

**Warning:** This appliance must be applied to potable water only. It is recommended that an independent Hague dealer install and maintain this appliance.

**Note:** The manufacturer reserves the right to make specification and product changes without prior notice.

This manual is for installation, operation, and maintenance of the following **WaterMax®** RO appliance models:

- H2000
- H2500
- H3000
- H3500
- LC30
- LC50
- LC100
- LC50P
- LC100P

## For Owner's Reference

Date of Installation: \_\_\_\_\_

Model Number: \_\_\_\_\_

Serial Number<sup>1</sup>: \_\_\_\_\_

Installer's Signature: \_\_\_\_\_

Dealership Name: \_\_\_\_\_

Dealership Address: \_\_\_\_\_

Dealership Phone Number: \_\_\_\_\_

Returned Warranty Card Date: \_\_\_\_\_

Hardness: \_\_\_\_\_

Iron: \_\_\_\_\_

pH: \_\_\_\_\_

Water Pressure: \_\_\_\_\_

Water Temp: \_\_\_\_\_

<sup>1</sup> The serial number is located on top of the mounting bracket.



## Introduction to Reverse Osmosis

Reverse Osmosis (RO), operates by removing contaminants from water at the molecular level. By using your household water pressure to squeeze your water against a special membrane, water molecules are separated from impurities. Rejected dissolved solids are automatically rinsed down the drain leaving only high-quality, delicious water for you to use.

### General Information

1. **WaterMax®** Reverse Osmosis Drinking Water Appliances replenish at about one-half gallon per hour, depending on your tap water pressure and the water temperature. Low water pressure and temperature will cause all RO appliances to produce a lower quantity of treated water. This appliance is designed with a self-regulating flush feature that limits the reject water to approximately four gallons for every gallon of permeate water. Your RO will perform better and last longer with heavy use. We encourage you to water house plants, provide water for pets, cook, mix drinks, fill batteries, etc., with RO water.

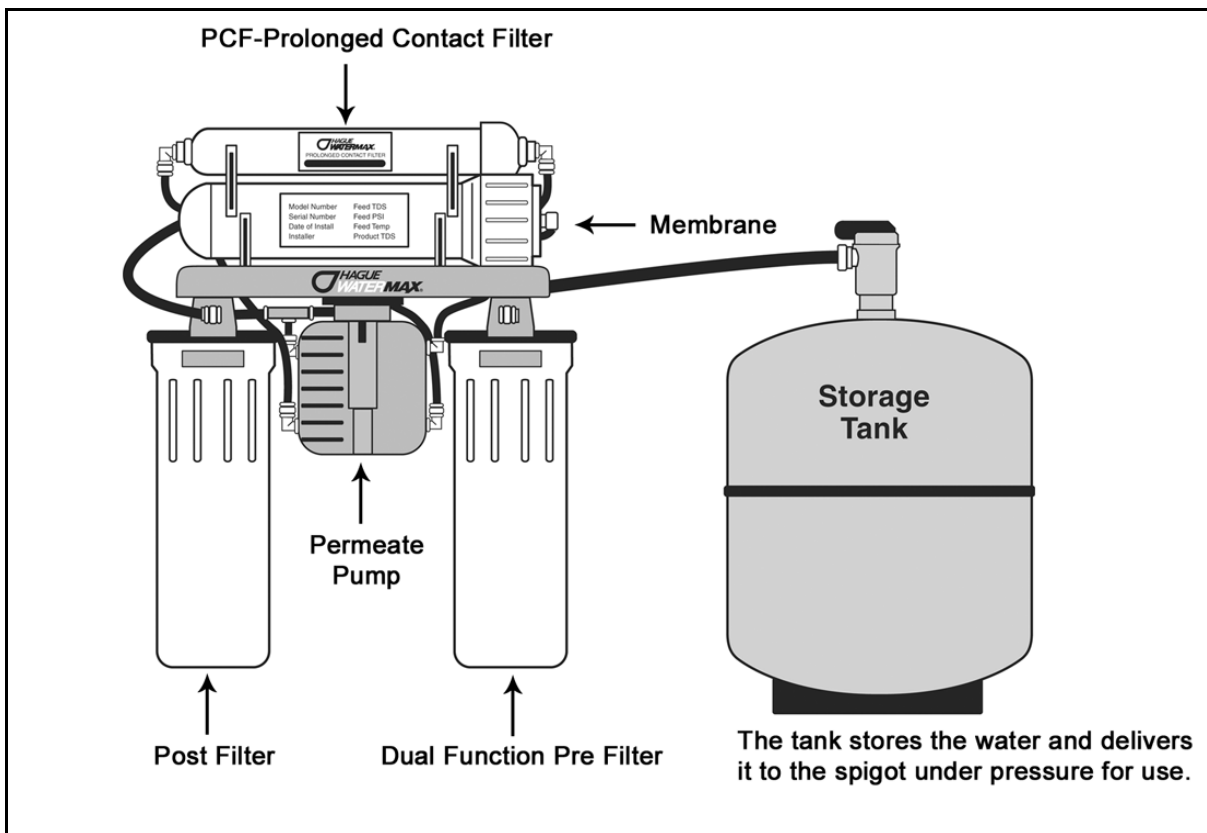

Figure 1: H3500 RO Appliance

## Introduction to Reverse Osmosis, Cont.

---

2. The storage tank will store between two and three gallons of water.

**Note:** The storage tank will operate in either a horizontal or a vertical position to permit convenient placement under your sink. Additional tanks may be added to your appliance to provide more storage, space permitting.

3. Your **WaterMax**® RO Drinking Water Appliance can be connected to your automatic ice maker and cold water dispenser in the refrigerator door. You may also want to install additional spigots in remote locations such as at a wet bar.
4. Your **WaterMax**® RO Drinking Water Appliance is designed to be used on cold water only. **Never run warm or hot water through your appliance.**

**Caution:** Connect to the cold water supply only!

**Warning:** Do not allow your appliance to freeze.

5. The rate that water will dispense through your treated water spigot will not be as strong as your regular sink faucet. The appliance is designed to operate at up to 90% of your regular sink water pressure.
6. The **WaterMax**® spigot has two dispensing positions. Push down on the black handle for intermittent flow, or lift the handle to a vertical position for continuous flow. The spout may be turned clockwise or counterclockwise for convenient use. The spigot handle may also be repositioned for your convenience.

## How Your Appliance Works

Your WaterMax® Drinking Water Appliance has been designed as a complete, self-contained appliance using three stages of primary filtration and separation. The frequency in which membranes and filters should be replaced depends upon the quality of the water that enters the appliance (feed water).

Meeting operational maintenance and replacement requirements are essential for this appliance to perform to specification. Contact your local dealer for replacement filters and parts, or contact Hague Quality Water International for the dealer nearest you.

### First Stage—The Pre-Filters

Your RO appliance uses one or more pre-filters to remove impurities before the feed water reaches the reverse osmosis membrane.

| Pre-Filter   | Model Number                           | Function  |
|--|--|---|
| Sediment   | H2000, H2500, H3000, LC30, LC50, LC100 | Removes suspended and particulate matter 5 microns or larger from the incoming tap water to protect the RO membrane and any Carbon Pre-Filter from clogging |
| Carbon   | H3000, LC30, LC50, LC100               | Removes free chlorine from the feed water and protects the membrane from chlorine degradation   |
| Dual-Function<br>(combination sediment and carbon) | H3500, LC50P LC100P                    | Protects the membrane from clogging and chlorine degradation  |

### **Sediment Pre-Filter Maintenance—Models H2000, H2500, H3000, LC30, LC50 and LC100**

If you are using softened water, replace your Sediment Pre-Filter annually. If you are not using softened water, the replacement interval will vary. Every six months, schedule an inspection and replace the Sediment Pre-Filter as necessary. If you notice a discoloration in the core (center) of the Sediment Pre-Filter and/or a heavy accumulation of sediment on the surface of the Sediment Pre-Filter, then replacement is necessary. The maximum recommended practical service life of the Sediment Pre-Filter is one year. The pre-filter is overdue for change when you notice reduced water production or a slower rate of flow.

**Note:** The Sediment Pre-Filter performance has not been tested or certified by NSF or WQA.

### **Carbon Pre-Filter Maintenance—Models H3000, LC30, LC50, and LC100**

Changing the Carbon Pre-Filter should be based on the free chlorine levels in the feed water. If the free chlorine is 1 ppm or less, then the Carbon Pre-Filter should be replaced once a year. If the free chlorine level is greater than 1 ppm, then the Carbon Pre-Filter should be replaced every six months.

**Note:** Models H3000, H3500, and LC30 also incorporate a special prolonged contact filter that further reduces chlorine and organics from your water supply.

### **Dual-Function Pre-Filter Maintenance—Models H3500, LC50P and LC100P**

Follow the same maintenance procedures as for the Sediment Pre-Filter.



## How Your Appliance Works, Cont.

---

### Second Stage—The Reverse Osmosis Membrane

The semi-permeable RO membrane separates the remaining suspended solids and most of the dissolved solids from the water molecules. Remaining impurities are washed down the drain.

#### *Maintenance*

The RO membrane is critical for effective reduction of total dissolved solids. The product water should be tested periodically to verify that the appliance is performing satisfactorily. The RO membrane should be changed when it rejects less than 75% of the dissolved solids. A noticeable change in water quality and taste may occur and indicates that a change is needed. Consult your Hague dealer for additional monitoring devices or water check programs.

**Note:** If your WaterMax® RO appliance is installed on a soft water supply, it will greatly increase the life of the membrane.

### Third Stage—Carbon Post-Filter

The Activated Carbon Post-Filter is the final stage of filtration depending on your model. It reduces tastes, odors, and chlorine.

#### *Maintenance*

Replace the Carbon Post-Filter at least once a year.

**Note:** The performance of the Carbon Post-Filter has not been tested or certified by NSF or WQA.

### Getting Maximum Efficiency From the Appliance

This appliance should be used only with potable water. It contains replaceable components critical to its efficiency. Replacement of the components should be with ones of identical specifications, as defined by Hague, to assure the same efficiency and contaminant reduction performance. See Performance Data Sheet.

# NSF-Performance Data Sheet



## Performance Data Sheet

Reverse Osmosis / Activated Carbon Drinking Water Appliance

Our Reverse Osmosis Drinking Water Appliances have been tested and conform to NSF/ANSI Standard 58 or WQA S-300. The water treatment performance for specific claims are substantiated and verified by the "Reduction Performance" test data listed below. The concentration of the indicated substances in water entering the appliances was reduced to a concentration less than or equal to permissible limits for water leaving the appliance, as specified in NSF/ANSI 58 or WQA S-300. While testing was performed under standard laboratory conditions actual performance may vary. H3000 and H3500 are certified by NSF and WQA to NSF/ANSI 58.

### Reduction Performance Model H3000 ( P/N 3146U )

| Contaminant               | ICC <sup>2</sup><br>mg/L | MPWC <sup>3</sup><br>mg/L | Average %<br>Rejection |
|---------------------------|--------------------------|---------------------------|------------------------|
| Arsenic (+5) <sup>†</sup> | 0.050±10%                | 0.010                     | 99.3                   |
| Barium*                   | 10.0±10%                 | 2.0                       | 99.8                   |
| Cadmium*                  | 0.03±10%                 | 0.005                     | 99.0                   |
| Chromium (3)*             | 0.30±10%                 | 0.05                      | 99.7                   |
| Chromium (6)*             | 0.30±10%                 | 0.05                      | 99.2                   |
| Cysts**                   | Min.50,000/mL            | 99.95%                    | 99.98%                 |
| Fluoride                  | 8.0±10%                  | 1.5                       | 97.0                   |
| Lead                      | 0.15±10%                 | 0.010                     | 99.4                   |
| Nitrate-N <sup>††</sup>   | 27±10%                   | 10.0                      | 94.3                   |
| Nitrite-N <sup>††</sup>   | 3.0±10%                  | 1.0                       | 82.1                   |
| Radium 226/228            | 25 pCi/L±10%             | 5pCi/L                    | 99.8                   |
| Selenium                  | 0.10±10%                 | 0.05                      | 94.0                   |
| TDS                       | 750±40 mg/L              | 187                       | 96.7                   |

### Reduction Performance Model H3500 ( P/N 2246U )

| Contaminant               | ICC <sup>2</sup><br>mg/L | MPWC <sup>3</sup><br>mg/L | Average %<br>Rejection |
|---------------------------|--------------------------|---------------------------|------------------------|
| Arsenic (+5) <sup>†</sup> | 0.050±10%                | 0.010                     | 99.3                   |
| Barium*                   | 10.0±10%                 | 2.0                       | 99.8                   |
| Cadmium*                  | 0.03±10%                 | 0.005                     | 99.0                   |
| Chromium (3)*             | 0.30±10%                 | 0.1                       | 99.7                   |
| Chromium (6)*             | 0.30 ±10%                | 0.1                       | 99.2                   |
| Cysts**                   | Min.50,000/mL            | 99.95%                    | 99.99                  |
| Fluoride                  | 8.0±10%                  | 1.5                       | 97.0                   |
| Lead                      | 0.15±10%                 | 0.010                     | 99.4                   |
| Nitrate-N <sup>††</sup>   | 27±10%                   | 10.0                      | 94.3                   |
| Nitrite-N <sup>††</sup>   | 3.0±10%                  | 1.0                       | 82.1                   |
| Radium 226/228            | 25 pCi/L±10%             | 5pCi/L                    | 99.8                   |
| Selenium                  | 0.10±10%                 | 0.05                      | 94.0                   |
| TDS                       | 750±40 mg/L              | 187                       | 96.2                   |

<sup>2</sup> Influent Challenge Concentration

<sup>3</sup> Maximum Permissible Water Concentration

### Test Parameters

|             |                 |
|-------------|-----------------|
| pH          | 7.5±0.5         |
| TDS         | 200-500 mg/L    |
| Temperature | 77± 2°F 25± 1°C |
| Turbidity   | ≤ 1 NTU         |
| Pressure    | 50±3 psig       |

\* This contaminant was tested at 750 mg/L ±40 mg/L TDS.

\*\* This appliance may be used on disinfected water that may contain filterable cysts.

<sup>†</sup> This appliance is acceptable for treatment of Nitrate / Nitrite with influent concentrations of no more than 27 mg/L of nitrate and 3 mg/L of nitrite combined measured as N and is certified for nitrate/nitrite reduction only for water sources with a water pressure of 40 psig or greater.

<sup>††</sup> This appliance has been tested for the treatment of water containing pentavalent arsenic (also known as As(V), As(+5), or arsenate) at concentrations of 0.30 mg/L or less. This appliance reduces pentavalent arsenic, but may not remove other forms of arsenic. This appliance is to be used on water supplies containing a detectable free chlorine residual at the appliance inlet or on water supplies that have been demonstrated to contain only pentavalent arsenic. Treatment with chloramine (combined chlorine) is not sufficient to ensure complete conversion of trivalent arsenic to pentavalent arsenic. Please see the Arsenic Facts section.

### WARNING!

These appliances must not be installed where the water source is microbiologically unsafe or of unknown quality without adequate disinfection before and/or after the appliance! A water source that is not potable relative to waterborne pathogens voids the warranty.

Operational maintenance and replacement requirements are essential for these appliances to perform to specification as advertised.

### FACTORS WHICH AFFECT THE LIFETIME AND PERFORMANCE OF YOUR WATERMAX® RO

1. TYPE OF MEMBRANE: Cellulose Tri-Acetate (CTA): Up to 1,200 PPM TDS with pressure of at least 40 PSI. Chlorine Tolerant- Some bacteria resistance- 5.0 to 9.0 pH- Excellent production rate- For use only with a chlorinated water supply.

Thin-Film Composite (TFC): Up to 2,000 PPM TDS with pressure of at least 40 PSI. Not chlorine tolerant- Bacteria resistant- 4.0 to 11.0 pH- Most advanced thin-film composite, non-cellulosic- Chemically stable- Highest production rate.

2. SQUARE FEET OF MEMBRANE: The square feet of membrane and the production of RO water are in direct proportions.

3. WATER PRESSURE: The higher the net pressure across the membrane, the greater the quantity of RO water. A minimum pressure of 40 PSI is recommended.

4. TOTAL DISSOLVED SOLIDS: The higher the TDS, the lower the production. Each 100 PPM represents about one PSI reduced pressure on the membrane. Thus, 1,000 PPM reduces the effective net pressure by 10 PSI.

5. WATER TEMPERATURE: Colder water results in lower production. Temperatures above 85 degrees F are to be avoided because of problems with the membrane support structures and accelerated compaction rates of CTA membranes. TFC may be used at temperatures up to 113 degrees F.

6. SURFACE COATING OR FOULING: A neglected pre-filter can allow sediment to accumulate on the cartridge surface and impair the necessary flow of water through the filter, thus reducing membrane life. Also, salts can precipitate on the membrane, plugging the pores and channels. A water softener or other types of pre-treatment installed before the RO appliance significantly reduces this load and extends membrane life.

Our Reverse Osmosis Drinking Water appliances contain replaceable treatment components, critical for the effective reduction of Total Dissolved Solids as well as inorganic contaminants. Each appliance will have some or all of the following replacement service components: Sediment pre-filter, sediment/carbon block pre-filter ( H3500 only ), activated carbon pre-filter, prolonged contact filter, activated carbon post-filter, flow restrictor and the membrane. (Please see replacement element diagrams on reverse side.) The life expectancy of these components will vary from one water source to another. Therefore, we recommend that you, the user, have the water tested every six months to maintain acceptable water quality. Operational, maintenance and replacement requirements are essential for these appliances to perform to specification. To maintain the highest quality water, we recommend draining the storage tank every week. Ask your dealer about maintenance programs or monitoring devices for any of our drinking water appliances.

# NSF—Performance Data Sheet, Cont.

## Performance Data Sheet

Reverse Osmosis/Activated Carbon Drinking Water Appliance

### General Operation Limits

|  | Model H3500 | Model H3000 |
|--|-------------|-------------|
| Membrane Type                          | TFC         | TFC         |
| Production, NSF <sup>1</sup> gpd (LPD) | 13 (49)     | 13 (49)     |
| Efficiency Rating <sup>3</sup>         | 17.9%       | 13%         |
| Recovery Rating <sup>4</sup>           | 21.4%       | 24%         |
| Pressure, Min-Max, psig                | 30-100      | 40-100      |
| Temperature, Min-Max, Deg. F           | 40°-113°    | 40°-113°    |
| Chlorine Tolerance, ppm <sup>2</sup>   | 0.0         | 0.0         |
| Hardness, Max grains                   | 10          | 10          |
| Iron, Max ppm                          | <0.1        | <0.1        |
| Manganese, Max ppm                     | <0.05       | <0.05       |
| pH, Min/Max                            | 4.0-11.0    | 4.0-11.0    |
| Hydrogen Sulfide, ppm                  | 0.0         | 0.0         |
| Turbidity, Max NTU                     | 1.0         | 1.0         |
| TDS, Max ppm                           | 2000        | 2000        |

<sup>1</sup> NSF production is measured against a pressure tank @ 5 psi backpressure, 77 degrees F, 50 psig and 750 mg/L ± 40 mg/L TDS.

<sup>2</sup> Models equipped with TFC membranes incorporate activated carbon as pretreatment for chlorine taste and odor.

<sup>3</sup> Efficiency Rating means the percentage of the influent water to the system that is available to the user as reverse osmosis treated water under operating conditions that approximate typical daily usage.

<sup>4</sup> Recovery Rating means the percentage of the influent water to the membrane portion of the system that is available to the user as reverse osmosis treated water when the system is operating without a storage tank or when the storage tank is bypassed.

Note: Actual production rate and TDS reduction will vary depending on water temperature, water pressure, TDS level, usage and membrane type.

**CAUTION!** Contaminants in excess of the established limits will require pretreatment.

**WARNING!** Do not use with water that is microbiologically unsafe or of unknown quality without adequate disinfection before and/or after the appliance.

### LIMITED 25 YEAR WARRANTY

25 years—Dispensing spigot, filter housings and caps,  
PCF housing and cap and membrane housing and cap.  
5 years—R.O. storage tank.

3 years—Membrane, 100% for the first year, then prorated from the beginning of the second year through the third year at 49%, plus 1-1/2% of the then current list price for each month the membrane has been in service.

2 years—Permeate pump (H3500 only) and automatic shutoff valve.

Filters—Are not warranted.

### REPLACEMENT ELEMENT DIAGRAMS AND ESTIMATED REPLACEMENT COSTS

Routine maintenance is essential for our products to function at peak performance. Estimated costs are listed with the part numbers. We strongly recommend changing the Sediment Pre-filter, Pre-carbon filter, Post-carbon filter and Prolonged contact filter every six months to one year or sooner depending on the quality of the feedwater source. Replace the membrane and the drain restrictor when the TDS rejection reaches 75% or less. The practical service life of the membrane is three years. Contact your local dealer for service and sanitizing for your Reverse Osmosis drinking water appliance.

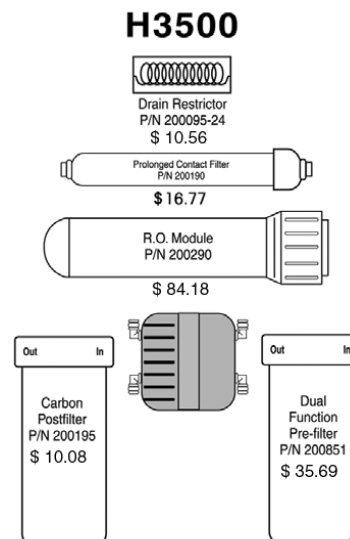
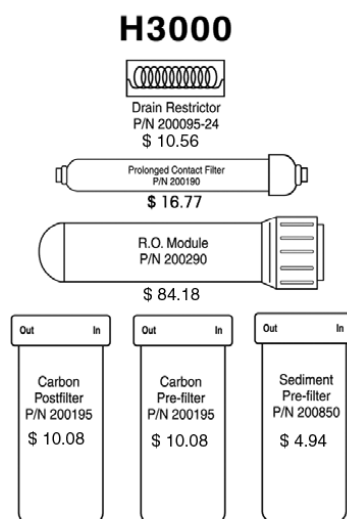

## Fact Section for Pentavalent Arsenic Treatment Appliances

Arsenic (As) is a naturally occurring contaminant found in many ground waters. It generally occurs in two forms (valences or oxidation states): pentavalent arsenic (also known as As(V), As(+5), or arsenate) and trivalent arsenic (also known as As(III), As(+3), or arsenite). In natural ground water, arsenic may exist as trivalent arsenic, pentavalent arsenic, or a combination of both. Although both forms of arsenic are potentially harmful to human health, trivalent arsenic is considered more harmful than pentavalent arsenic. More information about arsenic and its toxicity can be found on the U.S. Environmental Protection Agency Web site at <http://www.epa.gov/safewater/arsenic.html>.

These appliances (Model Numbers; H3000 and 3500) are designed to remove only pentavalent arsenic. These appliances do not provide a feature for conversion of trivalent arsenic to pentavalent arsenic. The appliances may remove some trivalent arsenic; however, they have not been evaluated to remove trivalent arsenic.

Trivalent arsenic is generally more difficult to remove from drinking water than pentavalent arsenic. Trivalent arsenic can be converted to pentavalent arsenic in the presence of an effective oxidant such as free chlorine. The arsenic in water containing detectable free chlorine or that has been treated with another effective oxidant will be in the pentavalent arsenic form.<sup>1</sup> Treatment with chloramines (combined chlorine) is not sufficient to ensure complete conversion of trivalent arsenic to pentavalent arsenic.

Consumers using public water supplies can contact their utility to verify whether free chlorine treatment chemicals are being used.

<sup>1</sup> Laboratory Study on the Oxidation of Arsenic III to Arsenic V, EPA/600/R-01/021, March 2001 available online at: <http://www.epa.gov/ORD/publications/ordpubs.html>

Private water supplies and waters that do not have detectable free chlorine residuals should be analyzed to determine the form(s) of arsenic present and the potential need for oxidation of trivalent arsenic to pentavalent arsenic.

Arsenic does not generally impart color, taste, or smell to water; therefore, it can only be detected by a chemical analytical test. Public water supplies are required to monitor treated water for total arsenic (trivalent arsenic plus pentavalent arsenic) and the results are available to the public from the utility. Consumers using private water sources will need to make arrangements for testing. A total arsenic test usually costs about \$15-\$30 and it is recommended the test be conducted by a certified laboratory. Local health departments and environmental protection agencies can help provide consumers with a list of certified laboratories. Some laboratories may also be able to analyze specifically for (speciate) the two forms of arsenic present in a water sample if requested.

These appliances were tested under laboratory conditions as defined in NSF/ANSI 58 Reverse Osmosis Drinking Water Treatment appliance and were found to reduce 0.30 mg/L in the test water to less than 0.010 mg/L, under standard testing conditions. Actual performance of the appliance may vary depending on specific water quality conditions at the consumer's installation. Following installation of the appliance, the consumer should have the treated water tested for total arsenic to verify arsenic reduction is being achieved and the appliance is functioning properly.

The pentavalent arsenic removal component of these appliances must be replaced at the end of its useful life (approx. 3 years). The replacement component #200290 can be purchased from the original source of this appliance (retailer or distributor), from other sources of these appliances, or directly from the manufacturer.

**Hague Quality Water**  
4343 S. Hamilton Rd.  
Groveport, OH 43125

## Checklist Before Installation

---

Refer to this checklist before each installation.

**WaterMax®** H2000 and H2500 are designed for chlorinated municipal water supplies.

A **WaterMax®** Water Softener or additional types of pretreatment are highly recommended should your water not meet water quality or characteristics standards. Should you have any questions about your water not meeting these standards, contact your Hague dealer.

- Water Quality**—If the water supply contains sand, sulfur, bacteria, iron bacteria, tannins, algae, oil, acid, or other unusual substances, consider pre-treating the water to remove these contaminants before the water supply enters the appliance, unless the appliance is represented as being capable of treating these contaminants in its specifications. Consider purchasing and installing a **WaterMax®** water conditioner or filter.
- Water Pressure**—Not less than 40 psi constant for **WaterMax®** RO appliances.
- Drain**—Drain the appliance to an appropriate drain, such as a floor drain or washer drain that complies with all local and state plumbing codes. To prevent back-siphoning, provide an adequate air gap or a siphon break. See *Installation Steps and Start-Up Procedures*.
- Water Characteristics: pH**—The appliance requires a pH of between 5.0 and 9.0 for H2000 and H2500 models and between 4.0 and 11.0 for other models to function properly.
- Water Characteristics: Iron and/or manganese**—A test to determine iron or manganese levels is necessary. Should iron exceed 0.1 ppm, or manganese exceed 0.05 ppm, additional pretreatment is recommended.

If you have any questions, contact your Hague dealer.

## Precautions

### Do

1. Comply with all state and local, building, plumbing, and electrical codes.
2. Check all fittings and locking clips to ensure none are loose.
3. Install the appliance after the pressure tank on well-water installations.
4. Connect to the cold water supply only!

### Do Not

1. Do not install if checklist items are not satisfactory. See *Checklist Before Installation*.
2. Do not install if the incoming or outlet piping water temperature exceeds 113°F. See *Specifications*.
3. Do not use to treat water that is microbiologically unsafe or of unknown quality without adequate disinfection before or after the appliance.
4. Do not allow your appliance to freeze.
5. Do not tie into hot water feed.

## Installation Tool List

The following are the tools you will need for installation.

| Recommended Tool List  | Optional Tool List                |
|--|-----------------------------------|
| 1/4" High-speed drill bit  | Needle nose pliers                |
| 7/16" High-speed drill bit   | 7/8" High-speed hole saw          |
| 1/2" High-speed drill bit, with 3/8" shank<br>(for non air gap spigot) | Air-pressure test gauge, 1-20 psi |
| 1" High-speed drill bit with 1/2" shank<br>(for air gap spigot)        | 7/8" chassis punch                |
| 1/2" Drill motor (for 1" high-speed drill bit)                         | Conductivity or TDS meter         |
| 1/2" Open-end wrench   | Water-pressure test gauge         |
| 9/16" Open-end wrench  | Bicycle tire pump                 |
| 5/8" Open-end wrench   | Silicon/carbide grinding wheel    |
| Medium-sized Phillips screwdriver                                      | High-speed Dremel tool            |



## Installation Diagram

### WaterMax® H2000, H2500, H3000, H3500, LC30, LC50, LC100, LC50P, and LC100P

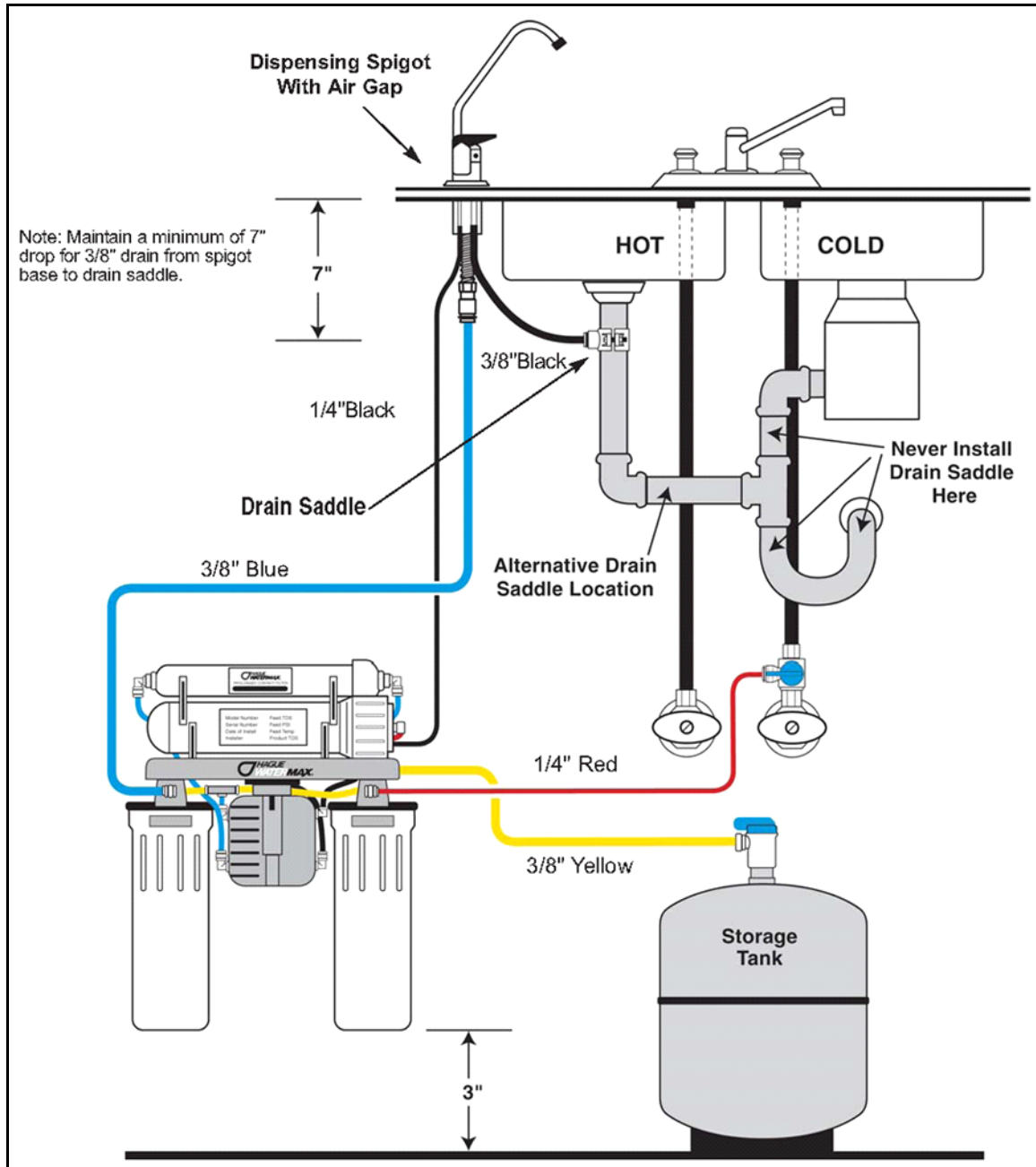

Figure 2: Installation Diagram

#### Notes:

1. For maximum flow, keep yellow tubing to tank and blue tubing to spigot as short as practical.
2. Install feed water line on COLD WATER LINE ONLY.
3. Installation procedures for the WaterMax® H2000, H2500, H3000, H3500, and LC30 are identical.

# Typical Flow Diagram

## Air Gap Silencer for H3500 and H2500

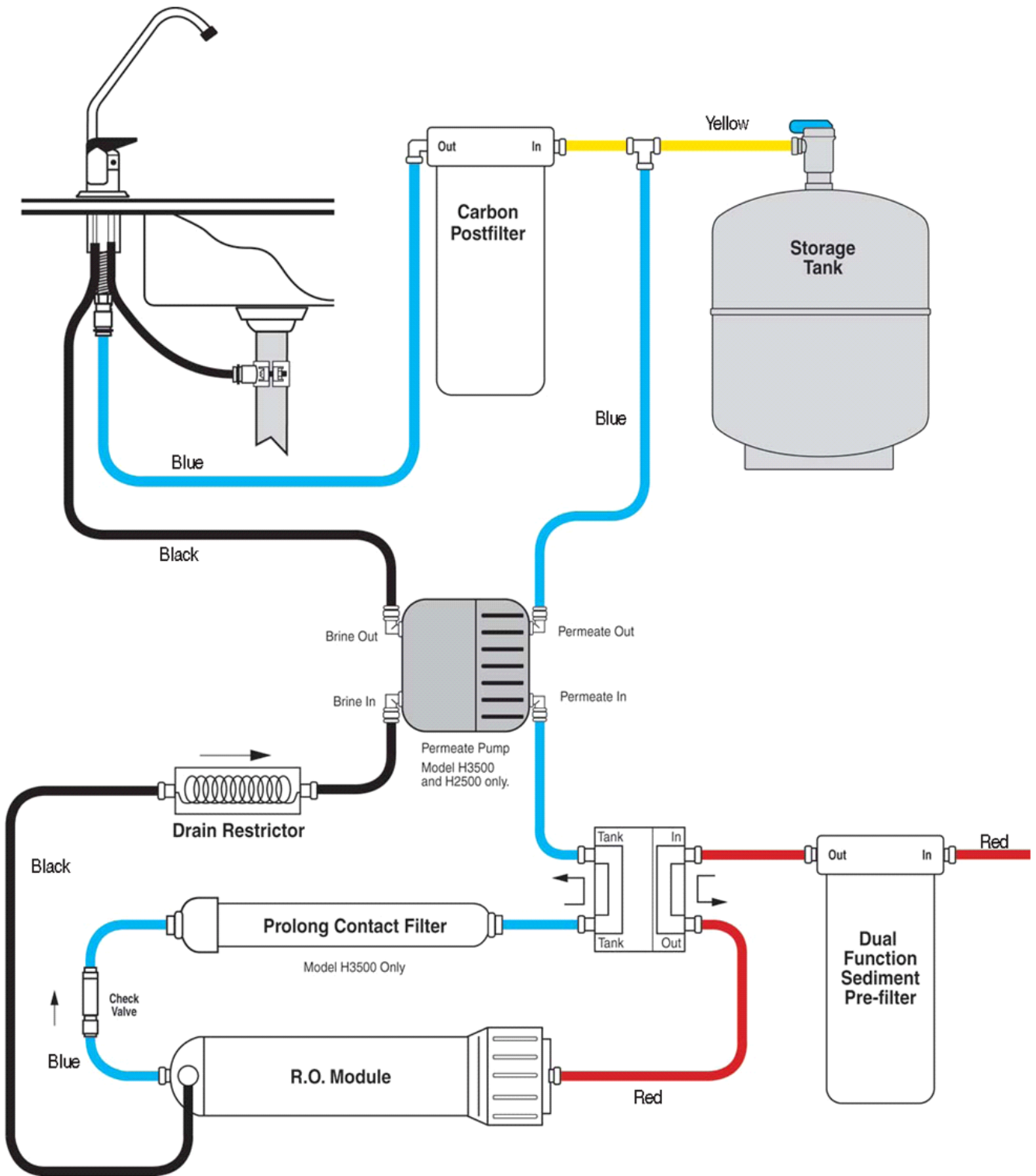

Figure 3: WaterMax® H3500 Flow Diagram



# Booster Pump Retrofit Diagrams

## WaterMax® H2000

For retrofit instructions see form #F0873

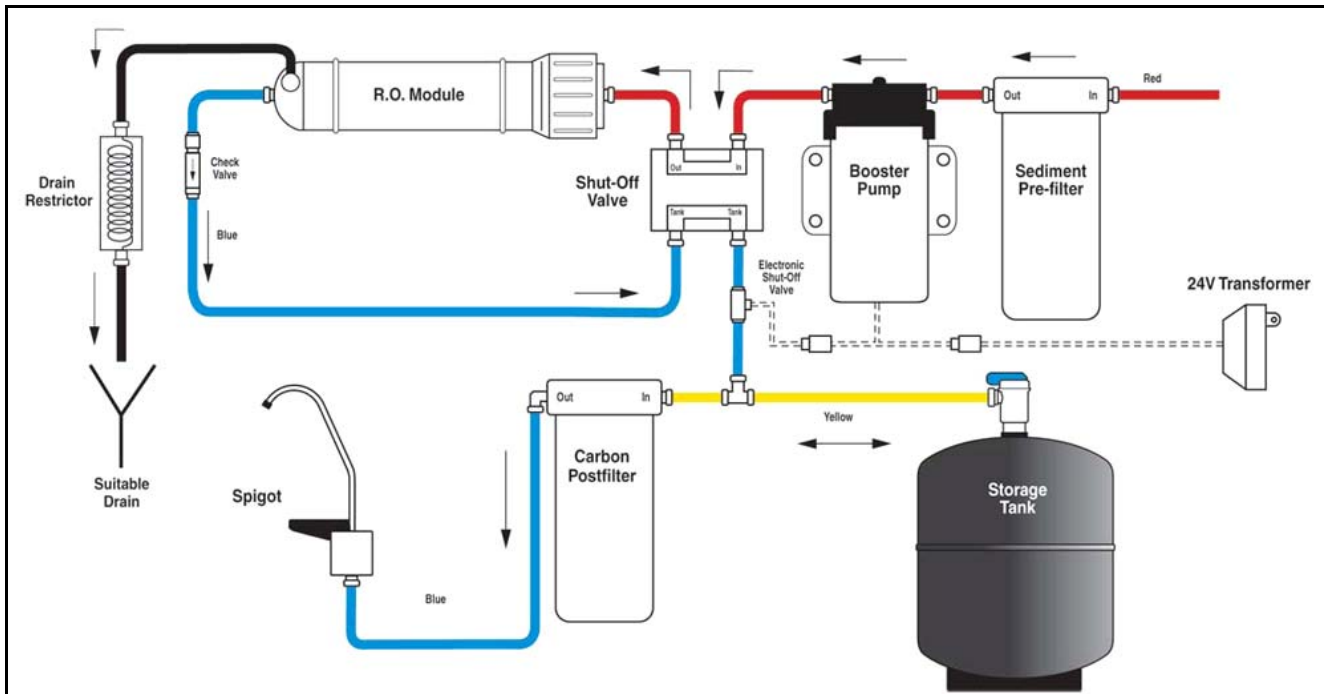

Figure 4: WaterMax® H2000

## WaterMax® H3000

For retrofit instructions see form #F0874

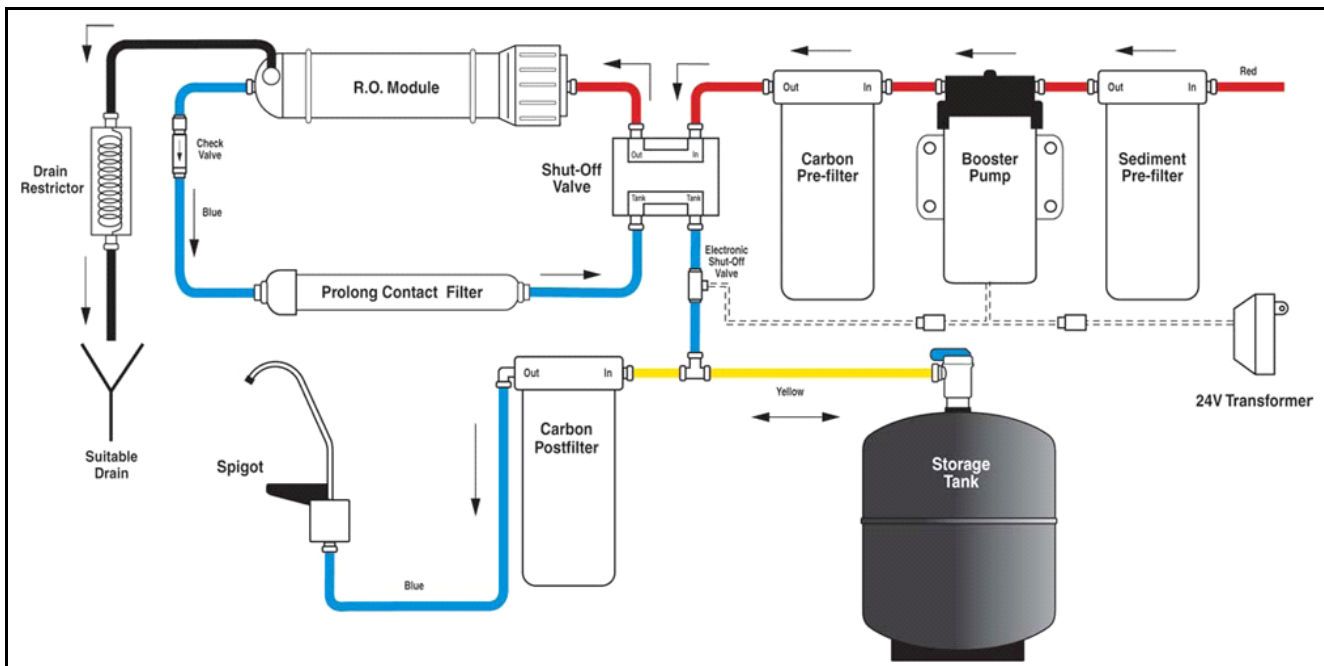

Figure 5: WaterMax® H3000

# Installation Steps and Start-Up Procedures

We recommend that you have your local Hague dealer install and service this appliance.

**Warning:** Installation of this appliance must conform with state and local plumbing and electrical codes, laws, regulations and the instructions provided with this appliance. Failure to install as instructed will void the product warranty.

## Step 1 *Study the Installation Diagram*

Study the overall installation diagram (See Figure 2) before proceeding, to familiarize yourself with the general layout of the appliance.

## Step 2 *Check Fit*

Ensure that the complete appliance will fit under the sink. Check all factory fittings<sup>1</sup> and tubing connections. Be sure all locking clips are in place. See steps A through F and the illustrations below for tube connection instructions.

### A. Cut tube square



Cut the tube square. It is essential that the outside diameter be free of score marks and that burrs and sharp edges be removed before inserting into fitting.

### B. Insert tube



The fitting grips before it seals. Ensure that the tube is pushed into the tube stop.

### C. Push up to tube stop

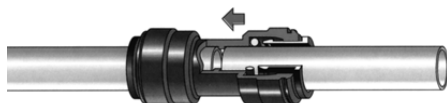

Push the tube into the fitting to the tube stop. The collet (gripper) has stainless-steel teeth that hold the tube firmly in position while the O-ring provides a permanent leak-proof seal.

### D. Insert the locking clip

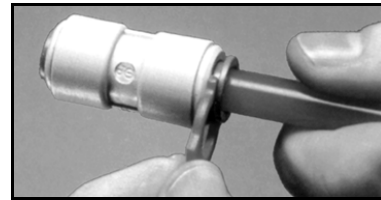

Insert the locking clip. The locking clip secures the collet in its position to prevent an accidental disconnection of the tube.

### E. Pull to check security



Pull on the tube to check that it is secure. Test the appliance before leaving the site or before use.

### F. Disconnecting

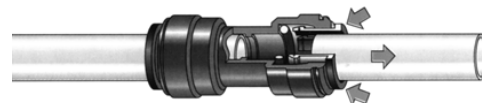

To disconnect, ensure that the appliance is depressurized. Remove the locking clip. Push in the collet squarely against the face of the fitting. With the collet held in this position, the tube can be removed. The fitting can then be re-used.

<sup>1</sup>The WaterMax<sup>®</sup> RO has been pressure tested. However, due to shipping vibrations, Hague recommends rechecking all factory fittings upon installation.

## Installation Steps and Start-Up Procedures, Cont.

### Step 3 *Install the Spigot Assembly*

The most convenient installation would allow the use of an existing spray attachment hole. If the spray attachment hole is not available, then follow the basic procedures outlined below.

#### Drilling a stainless steel sink:

- A. Mark the sink location for the center of the faucet.
- B. Impact punch the sink top to provide a starting point for the drill bit.
- C. Drill a 1/4" pilot hole in the sink using a high-speed drill bit.
- D. Drill a 1/2" diameter hole to accept the bolt of a 1-1/4" Greenlee Chassis Punch.
- E. Set the punch and turn the nut with a wrench to cut the hole. Follow Greenlee instructions.

#### Drilling a porcelain clad steel or cast iron sink:

- A. Mark the sink location for the center of the faucet. Be sure the location you select is not over a reinforcing rib. Check the location from below.
- B. Grind away a 1-1/4" diameter circle in the porcelain using a silicon/carbide wheel and high-speed grinder (See *Installation Tool List*), down to the metal surface of the sink. (See Figure 7)
- C. Impact punch a small indent in the center of the area ground away.
- D. Drill a 1/4" pilot hole through the metal base using a standard high-speed drill bit.

**Caution:** Be careful when the drill is about to penetrate the base metal of the sink. Reduce the speed and support the drill so the drill chuck does not impact the porcelain or enamel.

- E. Use the pilot hole as a guide to drill a minimum 1" up to a 1-1/4" diameter hole with carbide bits to mount the RO air gap spigot.

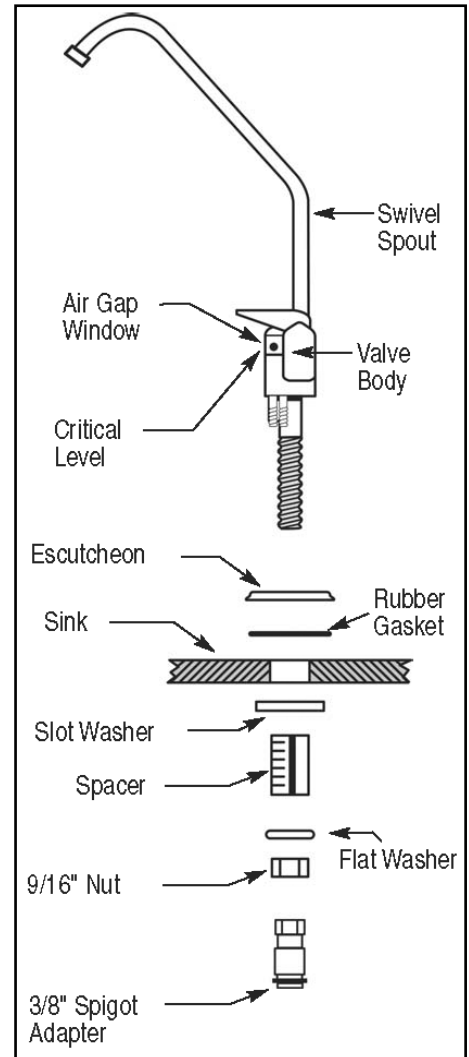

Figure 6: Air Gap Spigot Assembly

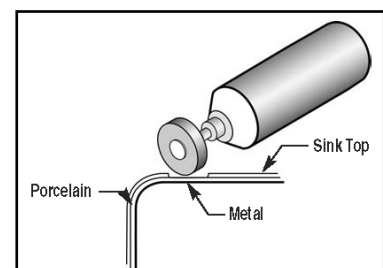

Figure 7: Grinding Wheel

## Installation Steps and Start-Up Procedures, Cont.

---

### Step 4

#### ***Prepare the RO Air Gap Spigot Assembly for Installation***

- A. Using the diagram in Figure 6, assemble the Air Gap Spigot with all the components except the slot washer. Begin with the escutcheon, followed by the rubber gasket, spacer, flat washer, 9/16" nut, and 3/8" spigot adapter.
- B. Using the diagram in Figure 2, from under the sink, feed the pre-connected 1/4" black tube and the pre-connected 3/8" blue tube from the RO assembly through the hole in the sink. Remove the red locking clip from the spigot adapter, slip the blue tube into the spigot adapter, and replace the red locking clip. Slip the 1/4" black tube onto the small hose barb on the base of the spigot.
- C. Slip one end of the loose 3/8" black tube over the large hose barb on the base of the spigot.

**Installation Tip:** To make it easier to slip the tubing over the hose barbs, soak the black tube ends in hot water to soften the tubing. The tubing will slip onto the hose barbs much more easily, and will conform better as it cools and reduce the possibility of splitting.

- D. Feed the assembled spigot and tubing through the hole in the sink and let the spigot rest on the rubber gasket and escutcheon.
- E. From under the sink, slip the slot washer between the sink and the spacer and finger-tighten the 9/16" nut until snug.
- F. Position the spigot for customer convenience and then use a 9/16" wrench to tighten the nut to secure the spigot on the sink.

## Installation Steps and Start-Up Procedures, Cont.

### Step 5

### *Install the Feed Water Supply Valve*

For Installation with Standard Angle Stop Water Supply Valve

- A. Shut off the water at the angle stop valve.
- B. Use a 5/8" open-end wrench to loosen the compression nut on the angle stop riser tube.
- C. Install the Feed Water Supply valve onto the angle stop. Use the 5/8" wrench to tighten the compression nut on the feed water supply valve. **Do not overtighten!**
- D. Reconnect the riser tube to the other end of the feed water supply valve. **Do not overtighten!**

**Caution:** A longer riser tube assembly will be required if a gentle loop cannot be made (See Figure 8).

- E. Remove the red locking clip from the feed water supply valve. Fully insert the red 1/4" tube into the speedfit connection and replace the red locking clip. The new feed water valve can be swiveled to position the tubing out of the way of under sink items.
- F. Make sure the feed water supply valve is off before turning the angle stop valve on. Check for leaks.

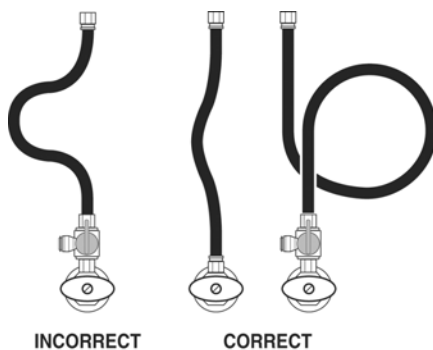

Figure 8: Flexible Hose Positions

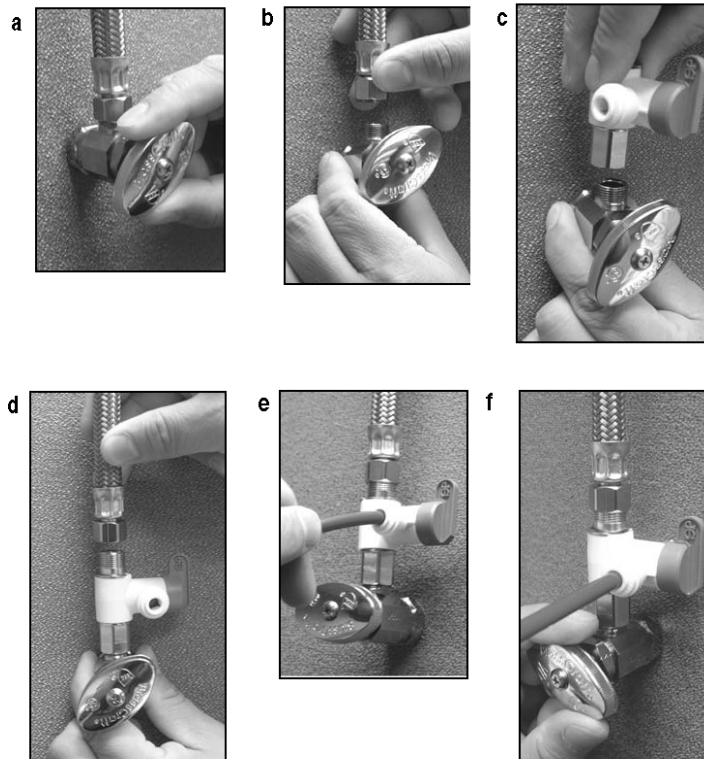

Figure 9: Installation With Flexible Hose

## Installation Steps and Start-Up Procedures, Cont.

### Step 6 *Install the Drain Saddle Assembly*

The drain assembly should be installed above the P-trap on the vertical or horizontal tailpiece. (See Figure 10.)

- A. Position the drain saddle in the desired location, mark the spot to be drilled, and remove the saddle. (See Figure 11.)
- B. Drill a 7/16" hole through one side of drain pipe only.
- C. Peel off the white backing from the drain gasket and apply the gasket to the "port" connection of the drain saddle (See Figure 15).

Make sure to align the drain saddle to the drilled hole. Attach the drain saddle to the drain pipe and tighten the two screws evenly.

- D. Cut the 3/8" black tube to desired length and connect to the drain saddle with the provided clip. (See Figure 2)

**Note:** State and local plumbing codes may prohibit the use of saddle valve connections.

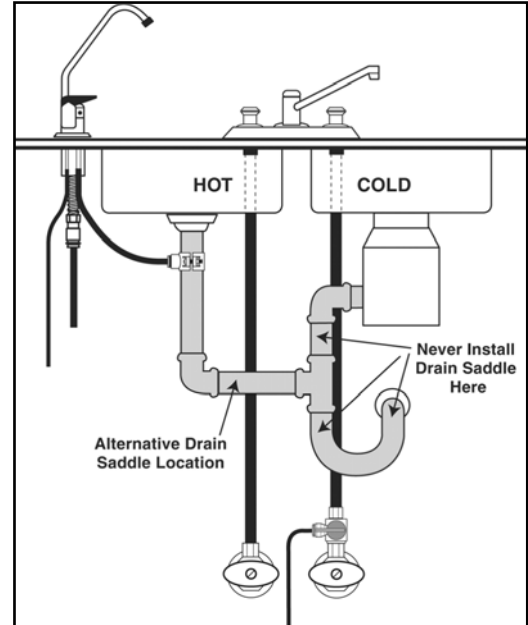

Figure 10: Drain Saddle Assembly Mounting Locations

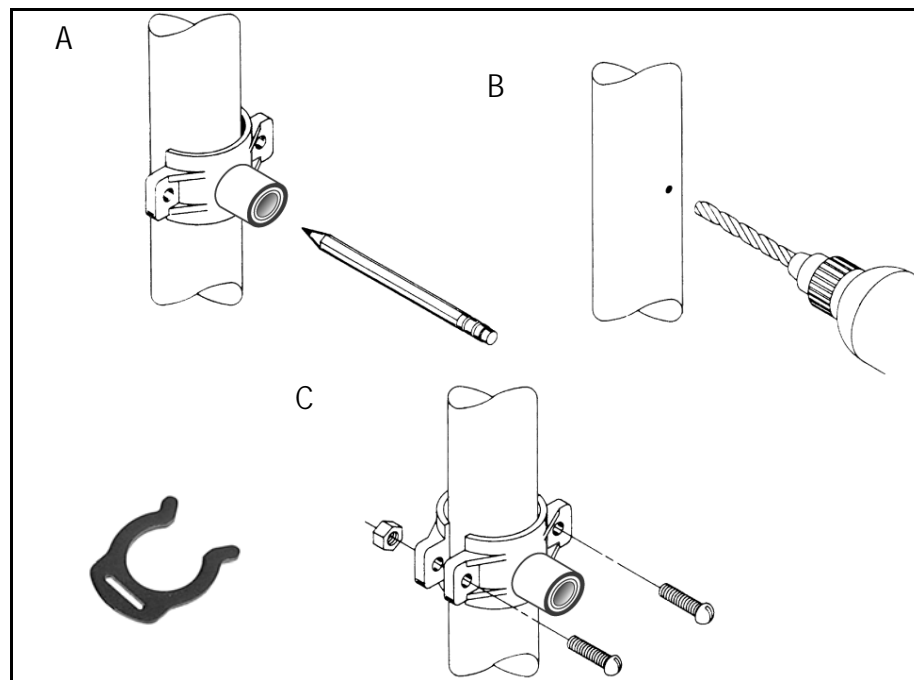

Figure 11: Drain Saddle Assembly

## Installation Steps and Start-Up Procedures, Cont.

---

### **Step 7** *Mount the Reverse Osmosis Appliance*

Mount the RO Appliance on the cabinet wall using the screws supplied. Leave 3" below the bottom of the filter housing for clearance when changing filters (See Figure 2).

### **Step 8** *Start-Up Procedure*

- A. Check all connections to ensure they are tight, with locking clips in place.
- B. Turn on the feed water and check for leaks.
- C. Open the valve on top of the storage tank.
- D. The appliance is now in operation.

### **Step 9** *Operation Procedure*

- A. Operation of the appliance will require two to five hours to initially fill the storage tank.
- B. After the storage tank is filled, open the spigot by lifting the black handle to the up position and drain the tank.
- C. After the tank has drained, return the black handle to the off position.
- D. Allow the storage tank to refill, and drain again. The water is now ready to use.



## Changing Filters

When replacing the primary filter of any RO appliance equipped with a permeate pump, be sure to follow the purge procedures exactly. Failure to do this may result in premature failure of the permeate pump due to an “air locked” condition created when entrained air enters the brine cavity of the permeate pump. This condition stalls the valves of the pump and will either stop brine flow or allow continuous flow to the drain.

**Note:** Whenever any filter is changed, sanitize the appliance. See *Sanitizing the WaterMax RO Appliance*.

**Caution:** Lubricate O-rings with glycerin. Never use a petroleum-based lubricant where it can contact the O-rings.

### Changing the Sediment Pre-Filter

1. Turn off the ball valve on top of the storage tank 1/4 turn clockwise. (See Figure 2).
2. Turn off the feed (cold) water supply valve. (See Figure 12).
3. Lift the black handle on the dispensing spigot and wait at least five minutes for the pressure to be relieved from the appliance.
4. Remove the Pre-Filter housing by turning it counterclockwise (as viewed from the bottom). If you encounter difficulty, use the filter wrench provided with your RO.
5. Inspect the Pre-Filter. If it is visibly dirty, discard it.
6. Wash out the filter housing using warm, soapy water and rinse thoroughly.
7. Sanitize the appliance. See *Sanitizing the WaterMax RO Appliance*.
8. Be sure the O-ring is properly seated in the groove that is located in the top of the filter housing and lubricated with glycerin.
9. Insert the new Pre-Filter. (For correct operation, the correct pre-filter designed for your particular model MUST be used). (See Figure 16).
10. Reattach the filter housing.
11. Purge the air out of the filter by removing the 1/4" locking clip from the elbow connection from the fitting in the “out” port on the Pre-Filter cap. (See Figure 17, Item 1).
12. Connect a suitable length of 1/4" tubing to the out port and route to the sink. Turn on the water supply and flush the filter until the water runs clear and steady.
13. Turn off the feed water supply and remove the flush tubing.
14. Reattach the red feed tube and the 1/4" locking clip to the fitting on the outlet fitting.
15. Turn on the feed water supply valve and check that the permeate pump is functioning properly. Let the water run for ten to fifteen minutes to confirm consistent performance.
16. Close the tank valve to check for proper shutoff valve function. When the permeate pump stops cycling, the water flow has shut off.

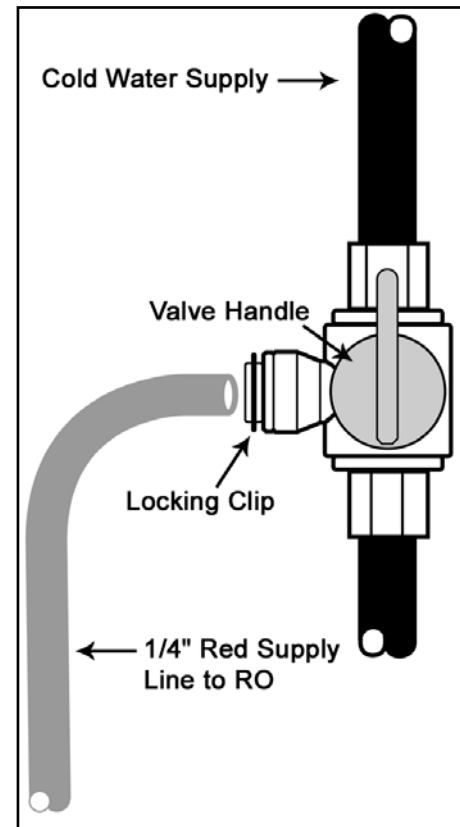

Figure 12: Feed Water Supply Valve



## Changing Filters, Cont.

---

17. Open the tank valve to allow the shutoff valve to open and resume normal operation of the RO. If the permeate pump does not begin to cycle, lift up on the black handle of the dispensing spigot and let the water run until the permeate pump begins to cycle.
18. Turn on the storage tank ball valve.
19. Inspect for leaks.

**Note:** With a new installation or after replacing the primary filter with the storage tank empty, it is normal for the water to run steady to the drain. The pump will start to cycle once the pressure starts to build in the storage tank. It may take up to 20 minutes for the permeate pump to cycle, which is normal.

### Changing the Carbon Pre-Filter

1. Turn off the ball valve on top of the storage tank 1/4 turn clockwise (See Figure 2).
2. Turn off the feed water supply valve.
3. Lift the black handle of the dispensing spigot and wait at least five minutes for the pressure to be relieved from the system.
4. Remove the Carbon Pre-Filter housing by turning it counterclockwise (as viewed from the bottom) and dispose of the spent cartridge. If you encounter difficulty, use the filter wrench provided with your RO.
5. Wash out the filter housing using warm soapy water and rinse thoroughly.
6. Be sure the O-ring is properly seated in the groove located in the top of the filter housing and lubricated with glycerin.
7. Sanitize the appliance. See *Sanitizing the WaterMax RO Appliance*.
8. Insert the new Carbon Pre-Filter of the same type and reattach the filter housing.
9. Follow steps 11–19 of Changing the Sediment Pre-Filter.

### Changing the Dual-Function Pre-Filter

Follow the instructions in *Changing the Sediment Pre-Filter*. Ensure that air is purged from the filter for any appliance equipped with a permeate pump.

## Changing Filters, Cont.

---

### Changing the Membrane

We strongly recommend that you seek the services of a Hague dealer to change your RO membrane, as well as perform a complete check-up and re-sanitize your appliance.

Be sure to order the proper type of membrane for your appliance: CTA or TFC. See *Assembly and Parts, RO Assembly*.

1. Turn off the ball valve on top of the storage tank 1/4 turn clockwise (See Figure 2).
2. Turn off the feed water supply valve.
3. Lift the black handle on the dispensing spigot and wait at least five minutes for the pressure to be relieved from the appliance.
4. Detach the red tubing connection on the pressure vessel end cap. (See Figure 18, Item 11.)
5. Remove the pressure vessel end cap by turning counterclockwise.
6. Remove the membrane, use needle nose pliers to grab the product tube and pull the membrane out of the housing.
7. Sanitize the appliance. (See *Sanitizing the WaterMax RO Appliance*).
8. Insert the new membrane, making sure that the brine seal (See Figure 16) and the product water O-rings are seated. Lubricate the brine seal and O-rings with glycerin.
9. Inspect the O-rings on the pressure vessel end cap and lubricate with glycerin. Replace if damaged or out of round.
10. Replace the end cap by turning clockwise.
11. Reattach the tubing to the pressure vessel end cap.

### Changing the Carbon Post-Filter

1. Turn off the ball valve on top of the storage tank 1/4 turn clockwise. (See Figure 2.)
2. Turn off the feed water supply valve.
3. Lift the black handle of the dispensing spigot and wait at least five minutes for the pressure to be relieved from the system.
4. Remove the Carbon Post-Filter housing by turning it counterclockwise (as viewed from the bottom) and dispose of the spent cartridge. If you encounter difficulty, use the filter wrench provided with your RO.
5. Wash out the Post-Filter housing using warm soapy water and rinse thoroughly.
6. Be sure the O-ring is properly seated in the groove located in the top of the post-filter housing and lubricate with glycerin.
7. Sanitize the storage tank. (See *Sanitizing the WaterMax RO Appliance*).
8. Insert the new Carbon Post-Filter of the same type and reattach the Post-Filter housing.
9. Turn on the feed water supply valve.
10. Turn on the storage tank valve.
11. Inspect for leaks.
12. Allow the first two tanks full of water to flush the Carbon Post-Filter before use.

## Sanitizing the WaterMax® RO Appliance

Sanitize the RO assembly and storage tank during installation and when replacing filters to prevent bad taste and odor in the drinking water. Common household chlorine bleach (5.25% - unscented) is suitable for this purpose.

**Hint:** Before you sanitize an RO appliance that has been in operation in a customer's home, the customer may wish to draw off some drinking water into a pitcher. It may be several hours until a sanitized RO appliance has generated sufficient clean water to meet their needs. Also, disconnect the icemaker to prevent it from freezing up, as well as any similar devices.

**Caution:** The procedures described below are for maintenance purposes only and are not intended to sterilize an appliance that has become heavily contaminated from misuse or neglect.

### Sanitize the RO Assembly

1. Close the feed water valve and open the RO spigot to drain any water from the storage tank. The tank should be light when picked up. If the tank is heavy, leave the spigot open and use a tire pump (See *Installation Tool List*) to pump air into the tank to displace the water. When the tank is drained, use a low-pressure tire gauge to adjust the air charge to between 5 and 7 psig.
2. Close the RO spigot.
3. Remove the pre-filter housing(s) and discard the spent cartridge(s). Wash out the housing(s) with warm water and soap using a bottlebrush and then rinse thoroughly with clear water to flush away any soap residue.

**Note:** Be sure all carbon pre- and post-filters are removed during the sanitizing procedure.

4. Insert the new cartridge(s) for the specific model.  
**Caution:** Do not touch the filter(s) with your bare hands. Peel the wrapper and use as a sleeve to prevent contamination. Wearing clean latex gloves can help prevent hand contact.
5. Pour 1 teaspoon (5 mL) of chlorine bleach directly down the center of the pre-filter cartridge so it will collect in the small cuplike centering device in the bottom of the housing. Keep the housing upright when attaching to the appliance to prevent spilling.  
**Note:** For model H3000 and LC 30, flush the Carbon Pre-Filter to remove the carbon fines. This will prevent fouling of the membrane. Pour 1 teaspoon (5 mL) of chlorine bleach into the top of the flushed Carbon Pre-Filter cartridge.
6. Open the feed water valve and let the water run to the drain until there is a strong chlorine odor at the end of the drain line. Shut off the feed water and let the RO sit for twenty minutes.
7. After twenty minutes, open the feed water valve and let the RO run for two to five hours.
8. Empty the tank and allow the appliance to refill. The water is now ready for use.

### Sanitize the Storage Tank

The two options outlined below are the most convenient ways to sanitize the storage tank of your drinking water appliance. Other methods may be used but require more complex procedures and apparatus typically used by a professional Hague service technician.

## Sanitizing the WaterMax® RO Appliance, Cont.

---

### Option 1

1. Close the feed water valve and open the RO spigot to drain any water from the storage tank. The tank should be light when picked up. If the tank is heavy, leave the spigot open; use a tire pump and pump air into the tank to displace the water. When the tank is drained, use a low-pressure tire gauge to adjust the air charge between 5 and 7 psig.
2. Close the RO spigot and close the valve on top of the storage tank 1/4 turn clockwise. (See Figure 2.)
3. Remove the red locking clip and disconnect the yellow tubing from the tank valve.
4. Place the tank in the sink with the valve port pointed away from you and open the valve 1/4 turn counterclockwise to rid the tank of any water not previously drained.
5. Add 1/2 teaspoon (3 mL) of chlorine bleach (5.25% - unscented) to the port of the tank valve.
6. Close the tank valve. Put the tank back in place and reinsert the yellow tube and red locking clip.
7. Open the feed water valve to pressurize the appliance and verify flow to the drain.
8. Open the tank valve and let the appliance run for two to five hours to fill the tank. Lift the spigot handle to empty the tank and allow the appliance to refill. The water is now ready for use.

### Option 2

Follow steps 1 and 2 as outlined above, then proceed as follows.

1. Remove the Pre-Filter housing and discard the spent cartridge. Wash out the housing with warm water and soap using a bottlebrush and then rinse thoroughly with clear water to flush away any soap residue.
2. Insert the new cartridge for the specified model.  
**Caution:** Do not touch the filter with your bare hands. Peel the wrapper and use as a sleeve to prevent contamination. Wearing clean latex gloves can help prevent hand contact.
3. Pour 1 teaspoon (5 mL) of chlorine bleach directly down the center of the Pre-Filter cartridge so it will collect in the small cuplike centering device in the bottom of the housing. Keep the housing upright when attaching to prevent spilling.
4. Remove the 1/4" red locking clip from the elbow on the "OUT" port of the pre-filter cap, (See Figure 17, Item 1). Disconnect the red tube.
5. Remove the 1/4" red locking clip from the 3/8" x 1/4" reducing tee, (See Figure 17, Item 9) and disconnect the 1/4" blue tube from the 1/4" branch of the reducing tee. Use a suitable length of 1/4" polyethylene tubing and connect to the elbow and tee connections.
6. Open the feed water valve and the tank valve and allow the sanitizing solution to flow to the tank for two to three minutes for the standard 3.1-gallon tank.
7. Close the tank valve and the feed water valve. Lift up on the spigot handle to depressurize the tank line and let the water flow until it stops and then close the spigot handle.
8. Remove the by-pass tubing and reconnect the red and blue tubes as well as the locking clips.
9. Open the feed water valve and the tank valve. Drain the tank after twenty to thirty minutes and allow the appliance to refill. The water is now ready for use.

## Assembly and Parts

### Feed Water Service Valve Assembly

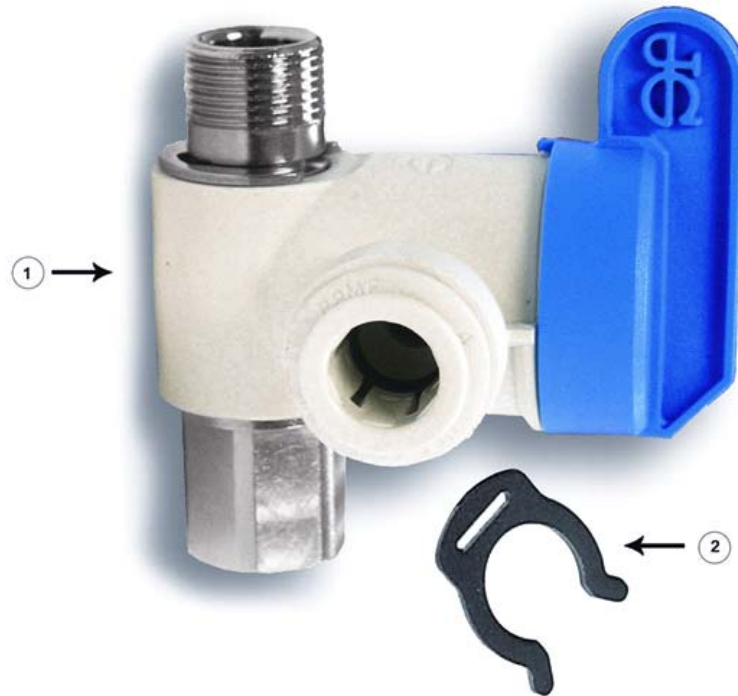

Figure 13: Feed Water Assembly

|   | Part # | Description                       | Quantity |
|---|--------|-----------------------------------|----------|
| 1 | 200540 | Feed Water Service Valve Assembly | 1        |
| 2 | 200200 | 1/4" Locking clip                 | 1        |

## Assembly and Parts, Cont.

### RO Air Gap Spigot (Lead Free)



Figure 14: RO Air Gap Spigot (Lead Free)

|   | Part # | Description                       | Quantity |
|---|--------|-----------------------------------|----------|
| 1 | 202310 | Filter housing wrench             | 1        |
| 2 | 200350 | Air gap spigot assembly           | 1        |
| 3 | 200360 | Spigot adapter, 3/8" x 7/16" J.G. | 1        |
| 4 | 200199 | Locking clip, 3/8"                | 1        |
| 5 | 10271  | Spigot rebuild kit                | 1        |

## Assembly and Parts, Cont.

### Drain Saddle Assembly

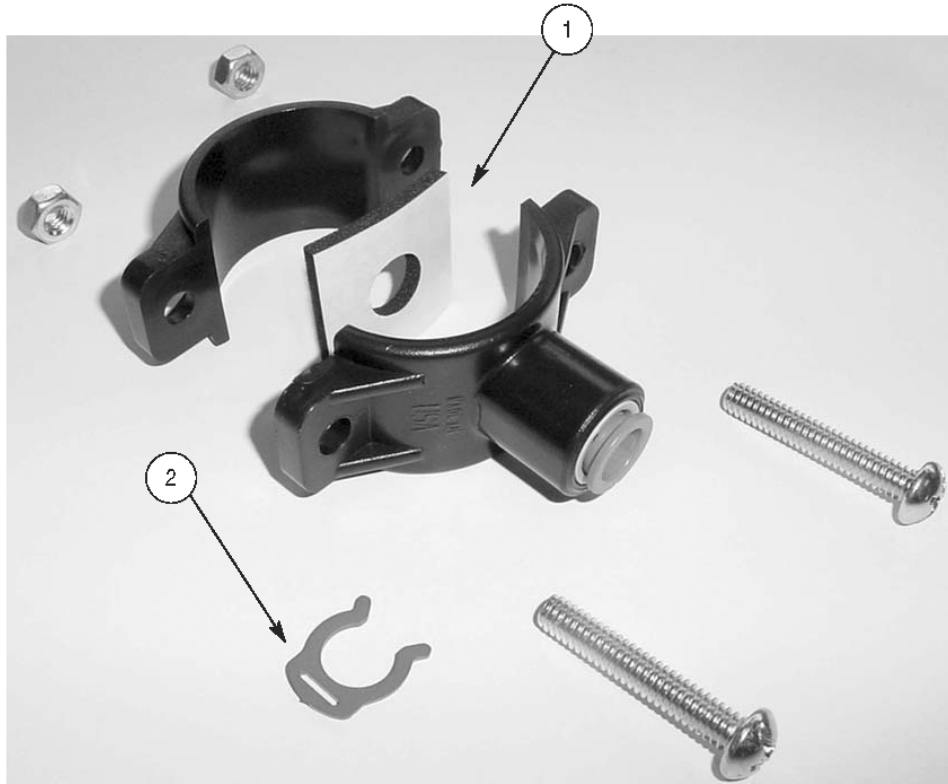

Figure 15: Drain Saddle Assembly

|   | Part #   | Description                              | Quantity |
|---|----------|--|----------|
| 1 | 200130JG | Drain saddle assembly, 2 Piece (Plastic) | 1        |
| 2 | 200199   | 3/8" Locking clip                        | 1        |



## Assembly and Parts, Cont.

### RO Assembly (Front View)



Figure 16: RO Assembly (Front View)



## Assembly and Parts, Cont.

### RO Parts (Front View)

|    | Part #    | Description                                      | Quantity |
|----|-----------|--|----------|
| 1  | 200412    | 20" sump housing 1/4" (LC50, LC100 not shown)    | 1        |
| 2  | 200460    | Filter sump                                      | 1        |
| 3  | 200408    | O-Ring, 10" filter sump                          | 1        |
| 4  | 200142    | 20" carbon cartridge (LC50, LC100 not shown)     | 1        |
| 5  | 200195    | Carbon Pre-Filter/Post-Filter, 10" GAC           | 1        |
| 6  | 200405    | Cap, 1/4" FPT                                    | 2        |
| 7  | 90816     | Male elbow, 3/8" x 1/4" (Plastic)                | 1        |
| 8  | 200199    | Locking clip, 3/8"                               | 1        |
| 9  | 200920    | 3/8" x 5' tubing, blue                           | 1        |
| 10 | 200045    | Bracket, all models                              | 1        |
| 11 | 200245HJG | Membrane housing, black                          | 1        |
| 12 | 200200    | Locking clip, 1/4"                               | 3        |
| 13 | 201030    | Male elbow, 1/4" x 1/4" (Plastic)                | 3        |
| 14 | 200190    | Prolonged contact filter, 12" H3000, H3500, LC30 | 1        |
| 15 | 200191    | Inline nitrate filter (Optional)                 | 1        |
| 16 | 201165    | Pressure vessel O-Ring                           | 1        |
| 17 | 200300    | CTA membrane, 16 GPD H2000, H2500                | 1        |
| 18 | 200290    | TFC membrane, 24 GPD H3000, H3500                | 1        |
| 19 | 200298    | TFC membrane, 36 GPD LC30, (Optional on H3500)   | 1        |
| 20 | 200295    | TFC membrane, 50 GPD LC50/P, LC100/P             | 1        |
| 21 | 200851    | Dual-Function Pre-Filter, H3500 only             | 1        |
| 22 | 200850    | Sediment Pre-Filter, 10" 5 Micron                | 1        |
| 23 | 200192    | 20" LC carbon filter, LC50P / LC100P (Not Shown) | 1        |
| 24 | 200144    | 20" sediment cartridge (LC50, LC100 not shown)   | 1        |
| 25 | 200910    | 1/4" x 5' tubing, red                            | 1        |
| 26 | F6026     | Label, membrane test                             | 1        |
| 27 | 200892    | Label, prolonged contact filter                  | 1        |
| 28 | 90845     | Label, Hague <b>WaterMax</b> <sup>®</sup>        | 1        |
| 29 | 200870    | Label, Sediment Pre-Filter                       | 1        |
| 30 | 200860    | Label, Carbon Pre-Filter                         | 1        |
| 31 | 200840    | Label, DFC Pre-Filter                            | 1        |
| 32 | 200890    | Label, Carbon Post-Filter                        | 1        |

## Assembly and Parts, Cont.

### RO Assembly (Back View)

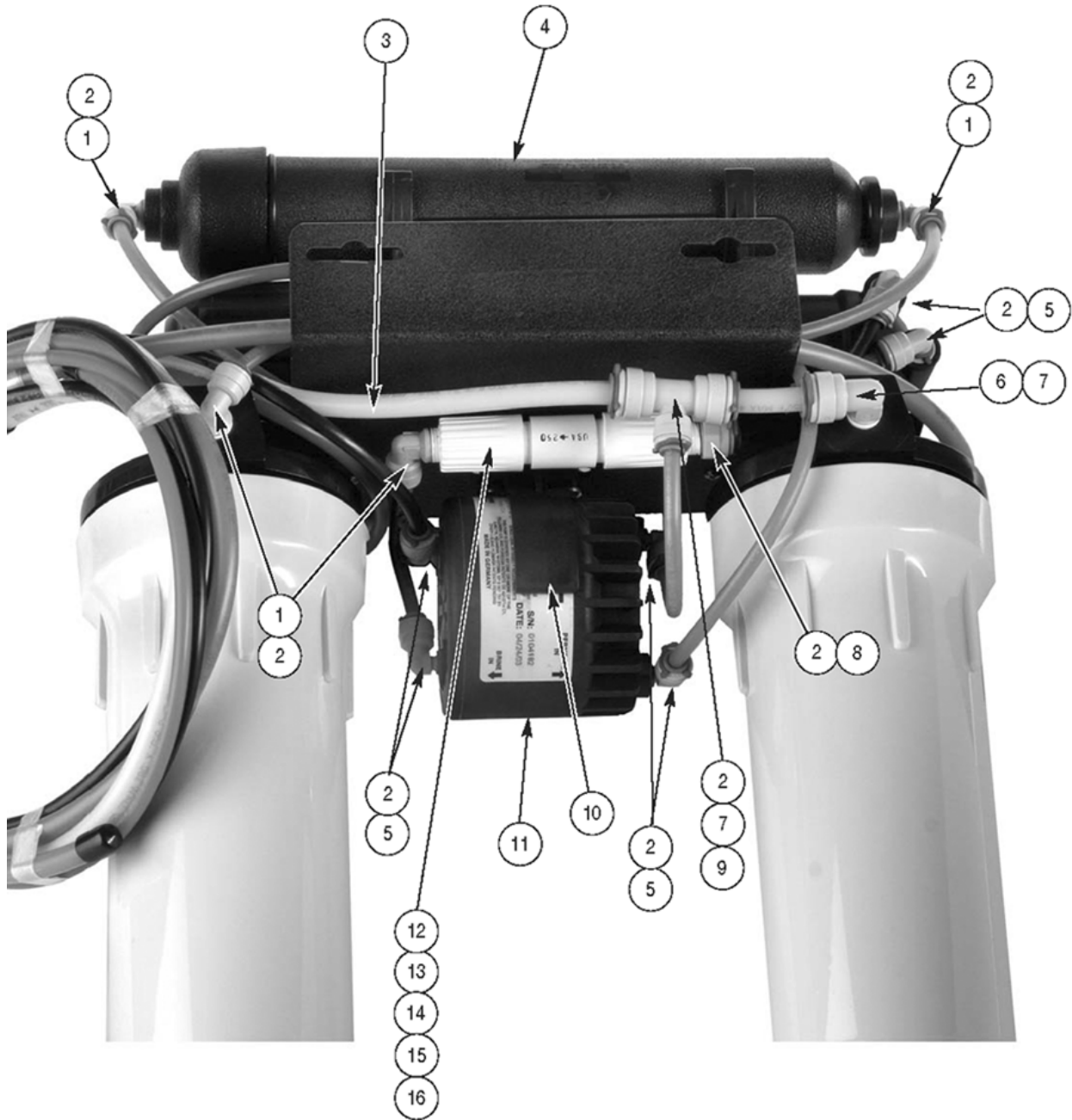

Figure 17: RO Assembly (Back View)

## Assembly and Parts, Cont.

### RO Parts (Back View)

|    | Part #     | Description   | Quantity |
|----|------------|---|----------|
| 1  | 201030     | Male elbow, 1/4" x 1/4" (Plastic)                                   | 4        |
| 2  | 200200     | Locking clip, 1/4"  | 12       |
| 3  | 200930     | 3/8" x 5' Tubing, yellow  | 1        |
| 4  | 200190     | Prolonged contact filter, 12"                                       | 1        |
| 5  | 202349     | Plug in elbow, 1/4" tube x 1/4" Stem                                | 6        |
| 6  | 90816      | Male elbow, 3/8" x 1/4" (Plastic)                                   | 1        |
| 7  | 200199     | Locking clip, 3/8"  | 3        |
| 8  | 201070     | Male connector, 1/4" x 1/4"   | 1        |
| 9  | 202356     | Reducing tee, 3/8" x 3/8" x 1/4" (Plastic)                          | 1        |
| 10 | PAMC       | Mounting clip, permeate pump  | 1        |
| 11 | PAM1000    | Permeate pump H2500, H3500, LC50P, LC100P                           | 1        |
| 12 | 200095-16  | Flow restrictor/pressure control, 170 mL/M, 16 GPD H2000, H2500     | 1        |
| 13 | 200095-24  | Flow restrictor/pressure control, 250 mL/M, 24 GPD H3000, H3500     | 1        |
| 14 | 200095-36  | Flow restrictor/pressure control, 380 mL/M, 36 GPD LC30, opt. H3500 | 1        |
| 15 | 200095-50  | Flow restrictor/pressure control, 525 mL/M, 50 GPD LC50 / 50P       | 1        |
| 16 | 200095-100 | Flow restrictor/pressure control, 1,050 mL/M, 100 GPD LC100 / 100P  | 1        |

## Assembly and Parts, Cont.

### RO Assembly (Top/Back View)



Figure 18: RO Assembly (Top/Back View)

## Assembly and Parts, Cont.

### RO Parts (Top/Back View)

|    | Part #    | Description   | Quantity |
|----|-----------|---|----------|
| 1  | J138-4    | 1/4" Check valve  | 1        |
| 2  | 200200    | Locking clip, 1/4"  | 12       |
| 3  | 202356    | Reducing tee, 3/8" x 3/8" x 1/4" (Plastic)                  | 1        |
| 4  | 200910    | 1/4" x 5' Tubing, red                                       | 1        |
| 5  | 200900    | 1/4" x 5' Tubing, black                                     | 1        |
| 6  | 200920    | 3/8" x 5' Tubing, blue                                      | 1        |
| 7  | 200930    | 3/8" x 5' Tubing, yellow                                    | 1        |
| 8  | 200199    | Locking clip, 3/8"  | 3        |
| 9  | 90816     | Male elbow, 3/8" x 1/4" (Plastic)                           | 1        |
| 10 | 202349    | Plug-in elbow, 1/4" tube x 1/4" Stem                        | 3        |
| 11 | 200245CJG | Membrane housing cap, black, with O-Ring                    | 1        |
| 12 | 201030    | Male elbow, 1/4" x 1/4"                                     | 2        |
| 13 | 200110    | 2" vessel clip  | 2        |
| 14 | 200410    | Automatic shutoff valve, H2000, H3000, LC-30, LC-50, LC-100 | 1        |
| 15 | PAMASV    | Permeate pump shutoff valve, H2500, H3500, LC50P, LC100P    | 1        |
| 16 | 200500    | Screw, 10-32  | 2        |
| 17 | 200501    | Hex nut, 10-32 Nylock                                       | 2        |
| 18 | 200115    | PCF to vessel clip  | 2        |
| 19 | 200310    | Sheet metal screw, #10 x 3/4", Phillips                     | 8        |

## Assembly and Parts, Cont.

### Storage Tank Assembly

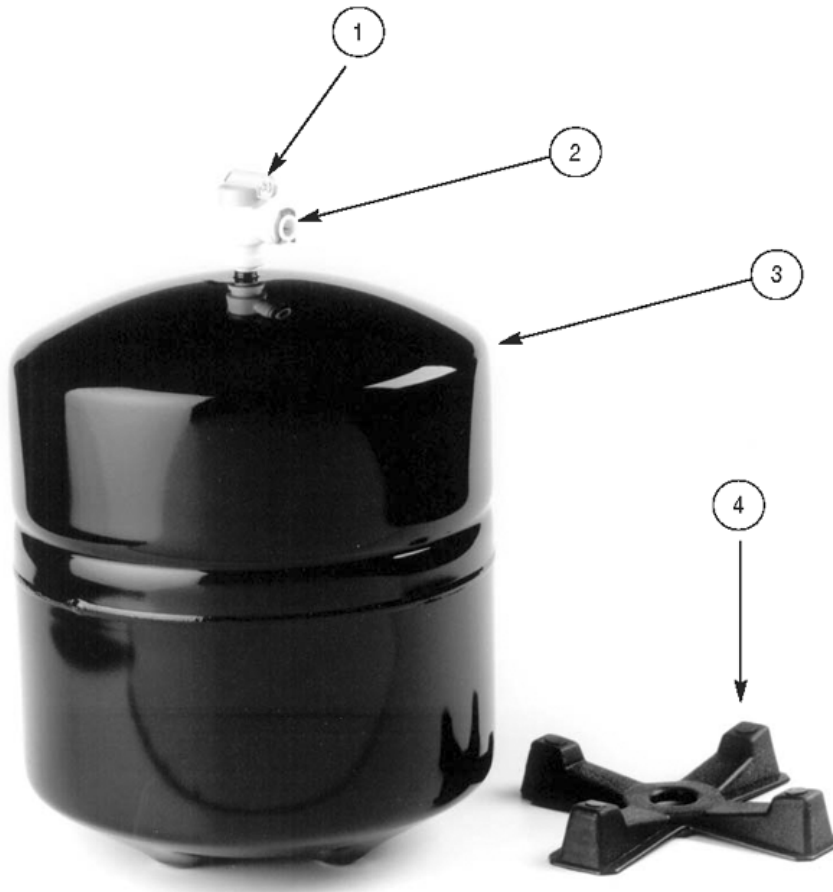

Figure 19: Storage Tank Assembly

|   | Part # | Description                                 | Quantity |
|---|--------|---|----------|
| 1 | 201140 | Tank shutoff valve, 3/8" x 1/4", plastic    | 1        |
| 2 | 200199 | 3/8" Locking clip                           | 1        |
| 3 | 200100 | RO storage tank, 3.1 gallon capacity, black | 1        |
| 4 | 200030 | Tank stand, plastic                         | 1        |

## Assembly and Parts, Cont.

### Parts-Booster Pump Kit P/N PAB6800KIT



Figure 20: Parts-Booster Pump Kit

|   | Part #  | Description           | Quantity |
|---|---------|-----------------------|----------|
| 1 | PAB6800 | Booster pump          | 1        |
| 2 | PAT115  | Transformer, 24VAC    | 1        |
| 3 | PAW260  | Pressure switch       | 1        |
| 4 | 200910  | 1/4" x 5' tubing, red | 1        |

## Optional Parts

| Part #   | Description                          | Quantity |
|--|--------------------------------------|----------|
| <b>Options, Permeate Pump Retrofit Kit - P/N PAM5000</b> |                                      |          |
| 200200   | Locking clip, 1/4"                   | 8        |
| PAM1000  | Permeate pump                        | 1        |
| 202349   | Plug in elbow, 1/4" tube x 1/4" stem | 4        |
| PAMC   | Mounting clip, permeate pump         | 1        |
| 200500   | Screw, 10-32 x 1/2", Phillips        | 2        |
| 200501   | Hex nut, 10-32 Nylock                | 2        |
| PAMASV   | Permeate pump shut-off valve         | 1        |
| <b>Options, Storage Tanks</b>                            |                                      |          |
| 200105   | 7.9 gallon pressure tank             | 1        |
| 200109   | 10.7 gallon pressure tank            | 1        |



## Troubleshooting

| Problem                      | Possible Cause  | Solution  |
|------------------------------|---|---|
| High product water TDS       | Membrane expended   | Replace Membrane module. Contact your local Hague dealer  |
|                              | Membrane attack by chlorine (Not applicable to CTA element)                     | Precarbon may be exhausted. Replace with a new cartridge and a new membrane                           |
|                              | Check valve failure   | Replace check valve. Contact your local Hague dealer  |
|                              | Insufficient brine flow rate-screen of flow restrictor pressure/control plugged | Replace or flush out screen and /or flow restrictor/pressure control. Contact your local Hague dealer |
|                              | A clogged pre-filter creates pressure drop and low brine flow                   | Replace the clogged pre-filter cartridge with a new one   |
|                              | Feed pressure too low   | See <i>Filter Specifications</i> chart to verify minimum feed pressure for your model                 |
|                              | Insufficiently flushed Carbon Post-Filter cartridge                             | Flush Carbon Post-Filter with product water. One or two tanks should be sufficient                    |
| No water or not enough water | Increase in feed water TDS  | Contact your local Hague dealer   |
|                              | Feed water shut off   | Turn on your feed water valve   |
|                              | Low feed pressure   | See <i>Filter Specifications</i> chart to verify minimum feed pressure for your model                 |
|                              | A pre-filter cartridge clogged  | Replace the clogged pre-filter cartridge with a new one   |
|                              | Screen in flow restrictor/pressure control plugged                              | Replace or flush out screen and/or flow restrictor/pressure control. Contact your local Hague dealer  |
|                              | Membrane fouled   | Determine and correct cause; replace membrane. Contact your local Hague dealer                        |
|                              | Product check valve stuck   | Replace check valve   |
|                              | Tank overpressurized  | Adjust air pressure between 5 and 7 PSI   |
|                              | Over use  | Contact your local Hague dealer   |
| Tank valve off               | Open tank valve   |   |
| Low flow rate from spigot    | Stalled permeate pump   | Confirm both product and reject flow into and out of permeate pump. Replace pump if necessary         |
|                              | Low water production  | See "No water or not enough water"  |
|                              | Tank lost air precharge   | Adjust air pressure between 5 and 7 PSI valve stem and tighten  |
|                              | Tank diaphragm slipped  | Replace tank  |
|                              | Carbon Post-Filter clogged  | Replace Carbon Post-Filter cartridge  |
| Tank valve partially closed  | Open tank valve   |   |

## Troubleshooting, Cont.

| Problem                                | Possible Cause   | Solution  |
|--|--|---|
| Bad tasting water                      | Increase in product TDS<br>Carbon Post-Filter exhausted<br>Tank and appliance contaminated<br><br>Tank contaminated<br>Tank diaphragm slipped<br>Carbon Post-Filter cartridge not flushed completely   | See "High product water TDS"<br>Replace Carbon Post-Filter cartridge<br>Replace Pre- and post-Filter, sanitize tank and appliance<br>Sanitize tank<br>Replace tank and postfilter cartridges<br>Flush one or two tanks of product water through Post-Filter |
| Cloudy water                           | Dissolved air in feed water, which is concentrated in product water  | This condition usually clears up eventually as the condition of feed water changes. Letting water stand will allow dissolved air to dissipate   |
| Cloudy ice cubes                       | Increase in product TDS<br>Dissolved air in feed water which is concentrated in product water<br>Certain ice cube shapes trap more dissolved air than others. The larger, more squared off cubes are the clearest. Smaller, rounded surface ice cubes are cloudier | See "High product water TDS"<br>Contact your local Hague dealer<br><br>Change ice cube mold shape, make cubes manually if using automatic. Let water sit to release dissolved air before freezing   |
| RO membrane is bad                     | Membrane fouled, hydrolyzed, ruptured or attacked by bacteria  | Replace membrane  |
| Pre- or Post-Filter leaks from housing | Deformed or stretched O-ring or housing not tight  | Replace O-ring and clean seating surface or tighten housing   |
| Flow/pressure control plugged          | Dirt or debris plugging flow restrictor tube   | Replace flow restrictor/pressure control  |
| Spigot-valve leaks through spout       | Valve seat is defective  | Repair spigot assembly, P/N 10271   |
| Air gap overflows                      | Debris is lodged in 3/8" tube from air gap to drain  | Disconnect the tube from drain saddle and clean out debris  |
| Handle breaks off                      | Fatigue or misuse  | Repair spigot assembly, P/N 10271   |
| Spout breaks off                       | Fatigue or misuse  | Replace spout assembly, P/N 200350  |
| Valve leaks around stem                | Fatigue  | Replace stem assembly, P/N 10271  |
| Leak at base of spout                  | Fatigue  | Repair spigot assembly, P/N 10271   |
| Tank-Loss of Air                       | Tank may lose air over a period of time  | Adjust air pressure between 5 and 7 PSI   |
| Slipped diaphragm                      | Pressure exceeds diaphragm strength due to combination of high feed pressure and low precharge, or defective tank  | Replace tank  |

## RO Specifications

| Model Part #                           | H2000<br>2056U         | H2500<br>2256U         | H3000 <sup>1</sup><br>3146U      | H3500 <sup>1</sup><br>2246U      | LC 30<br>N/A                     | LC 50/50P<br>N/A                 | LC 100/100P<br>N/A               |
|--|------------------------|------------------------|----------------------------------|----------------------------------|----------------------------------|----------------------------------|----------------------------------|
| Membrane                               | CTA                    | CTA                    | TFC                              | TFC                              | TFC                              | TFC                              | TFC                              |
| Production Rates                       |                        |                        |                                  |                                  |                                  |                                  |                                  |
| Gallons per day <sup>2</sup>           | 16                     | 16                     | N/A                              | N/A                              | 30                               | 50                               | 100                              |
| Liters per day <sup>2</sup>            | 60.5                   | 60.5                   | N/A                              | N/A                              | 50                               | 189                              | 378                              |
| NSF GPD <sup>3</sup>                   | N/A                    | N/A                    | 13                               | 13                               | N/A                              | N/A                              | N/A                              |
| NSF LPD <sup>3</sup>                   | N/A                    | N/A                    | 49                               | 49                               | N/A                              | N/A                              | N/A                              |
| Water Pressure (Min-Max)               | 40-100                 | 40-100                 | 40-100                           | 40-100                           | 40-100                           | 40-100                           | 40-100                           |
| Water Temperature Degrees, F (Min-Max) | 40-85                  | 40-85                  | 40-113                           | 40-113                           | 40-113                           | 40-113                           | 40-113                           |
| Chlorine Tolerance (ppm)               | 0.5-1.5                | 0.5-1.5                | 0                                | 0                                | 0                                | 0                                | 0                                |
| Max. Hardness (Gr. pg)                 | 10                     | 10                     | 10                               | 10                               | 10                               | 10                               | 10                               |
| Max. Iron (ppm)                        | < 0.1                  | < 0.1                  | < 0.1                            | < 0.1                            | < 0.1                            | < 0.1                            | < 0.1                            |
| Max. Mang. (ppm)                       | < 0.05                 | < 0.05                 | < 0.05                           | < 0.05                           | < 0.05                           | < 0.05                           | < 0.05                           |
| pH Limit                               | 5.0-9.0                | 5.0-9.0                | 4.0-11.0                         | 4.0-11.0                         | 4.0-11.0                         | 4.0-11.0                         | 4.0-11.0                         |
| Max. TDS Limit (ppm)                   | 1200                   | 1200                   | 2000                             | 2000                             | 2000                             | 2000                             | 2000                             |
| Hydrogen Sulfide (ppm)                 | 0.00                   | 0.00                   | 0.00                             | 0.00                             | 0.00                             | 0.00                             | 0.00                             |
| Max. Turbidity (NTU)                   | 1.0                    | 1.0                    | 1.0                              | 1.0                              | 1.0                              | 1.0                              | 1.0                              |
| TDS Rejection                          |                        |                        |                                  |                                  |                                  |                                  |                                  |
| Typical @ 60 psi                       | 95%-97%                | 95%-97%                | N/A                              | N/A                              | 97%-98%                          | 97%-98%                          | 97%-98%                          |
| NSF @ 50 psi                           | N/A                    | N/A                    | 96.7%                            | 96.2%                            | N/A                              | N/A                              | N/A                              |
| Storage (Gal.)                         | 3.1                    | 3.1                    | 3.1                              | 3.1                              | 3.1                              | Optional                         | Optional                         |
| Water Supply                           | Municipal, Chlorinated | Municipal, Chlorinated | Municipal, Well, Non-Chlorinated | Municipal, Well, Non-Chlorinated | Municipal, Well, Non-Chlorinated | Municipal, Well, Non-Chlorinated | Municipal, Well, Non-Chlorinated |
| Treatment Stages                       | 3                      | 3                      | 5                                | 5                                | 5                                | 4 <sup>4</sup>                   | 4 <sup>4</sup>                   |
| Prefiltration                          | 5 Micron Sediment      | 5 Micron Sediment      | 5 Micron Sediment, GAC           | 1 Micron Sediment/ Carbon Block  | 5 Micron Sediment, GAC           | 5 Micron, 20" Sediment, GAC      | 5 Micron, 20" Sediment, GAC      |
| PCF                                    | N/A                    | N/A                    | Standard                         | Standard                         | Standard                         | N/A                              | N/A                              |
| Postfilter                             | GAC                    | GAC                    | GAC                              | GAC                              | GAC                              | GAC                              | GAC                              |
| Height                                 | 15 1/4"                | 15 1/4"                | 16 3/4"                          | 16 3/4"                          | 16 3/4"                          | 28"                              | 28 3/4"                          |
| Width                                  | 14 1/2"                | 14 1/2"                | 14 1/2"                          | 14 1/2"                          | 14 1/2"                          | 14 1/2"                          | 14 1/2"                          |
| Depth                                  | 7"                     | 7"                     | 7"                               | 7"                               | 7"                               | 7"                               | 7"                               |
| Weight                                 | 29 lb                  | 29 lb                  | 35 lb                            | 35 lb                            | 35 lb                            | 38 lb                            | 40 lb                            |
| Efficiency Rating <sup>5</sup>         | N/A                    | N/A                    | 13%                              | 17.9%                            | N/A                              | N/A                              | N/A                              |
| Recovery Rating <sup>6</sup>           | N/A                    | N/A                    | 24%                              | 21.4%                            | N/A                              | N/A                              | N/A                              |

<sup>1</sup> H3000 and H3500 are certified by NSF and WQA to NSF/ANSI 58 for the specific performance claims as verified and substantiated by the test data. These are the only units certified by WQA and NSF.

<sup>2</sup> Product output is measured to atmosphere with feed water of 77 degrees F, 60 PSIG and 360 ppm TDS.

<sup>3</sup> NSF production is measured against a pressure tank @ 5 psi backpressure, 77 degrees F, 50 PSIG and 750 mg/L ± 40 mg/L TDS, 1 NTU turbidity 7.5 ± 0.5 pH, 1 US/cm.

<sup>4</sup> LC50P and LC100P use dual function prefilter for chlorine taste and odor removal.

**Note:** Actual production rates may vary depending on water temperature, pressure, TDS level and membrane type.

<sup>5</sup> Efficiency Rating means the percentage of the influent water to the system that is available to the user as reverse osmosis treated water under operating conditions that approximate typical daily usage.

<sup>6</sup> Recovery Rating means the percentage of the influent water to the membrane portion of the system that is available to the user as reverse osmosis treated water when the system is operating without a storage tank or when the storage tank is bypassed.

# Certificates

State of California  
Department of Health Services  
**Water Treatment Device  
Certificate Number**

05 - 1692

Date Issued: December 21, 2005

|   |  |
|---|--|
| <u>Trademark/Model Designation</u><br>Water Max H3000 (3146U) | <u>Replacement Elements</u><br>200290 RO Membrane<br>200195 (2) Pre and Post filter<br>200850 Sediment Pre filter<br>200190 Prolonged contact filter |
| <u>Manufacturer:</u> Hague Quality Water International        |  |

The water treatment device(s) listed on this certificate have met the testing requirements pursuant to Section 116830 of the Health and Safety Code for the following health related contaminants:

|   |  |
|---|--|
| <u>Microbiological Contaminants and Turbidity</u> | <u>Inorganic/Radiological Contaminants</u> |
| Cysts   | Arsenic <sup>1</sup> (pentavalent)         |
|   | Barium                                     |
|   | Cadmium                                    |
|   | Chromium (hexavalent)                      |
|   | Chromium (trivalent)                       |
| <u>Organic Contaminants</u>                       | Fluoride                                   |
| None  | Lead                                       |
|   | Nitrate <sup>2</sup>                       |
|   | Nitrite <sup>2</sup>                       |
|   | Radium 226/228                             |
|   | Selenium                                   |

Rated Service Capacity: N/A

Rated Service Flow: 20 gpd

Conditions of Certification:

Do not use where water is microbiologically unsafe or with water of unknown quality, except that systems certified for cyst reduction may be used on disinfected waters that may contain filterable cysts.

<sup>1</sup> Claims for arsenic reduction shall only be made on water supplies maintaining detectable residual free chlorine at the reverse osmosis (RO) system inlet. Water systems using an in-line chlorinator should provide a minimum of 1 minute chlorine contact time before the RO system.

<sup>2</sup>This system is acceptable for treatment of influent concentrations of no more than 27 mg/L nitrate and 3 mg/L nitrite in combination measured as N and is certified for nitrate/nitrite reduction only for water supplies with a pressure of 280 kPa (40 psig) or greater. A sampling and analysis test kit for nitrate is provided for checking the performance of this system. Frequent analysis is encouraged.

# Certificates, Cont.

State of California  
Department of Health Services  
Water Treatment Device  
Certificate Number

05 - 1693

Date Issued: December 21, 2005

|   |  |
|---|--|
| <u>Trademark/Model Designation</u><br>Water Max H3500 (2246U) | <u>Replacement Elements</u><br>200290 RO Membrane<br>200195 Post filter<br>200190 Prolonged contact filter<br>200851 Dual function prefilter |
| <u>Manufacturer:</u> Hague Quality Water International        |  |

The water treatment device(s) listed on this certificate have met the testing requirements pursuant to Section 116830 of the Health and Safety Code for the following health related contaminants:

|   |  |
|---|--|
| <u>Microbiological Contaminants and Turbidity</u> | <u>Inorganic/Radiological Contaminants</u>   |
| Cysts   | Arsenic <sup>1</sup> (pentavalent)<br>Barium<br>Cadmium<br>Chromium (hexavalent)<br>Chromium (trivalent)<br>Fluoride<br>Lead<br>Nitrate <sup>2</sup><br>Nitrite <sup>2</sup><br>Radium 226/228<br>Selenium |
| <u>Organic Contaminants</u>                       |  |
| None  |  |

Rated Service Capacity: N/A

Rated Service Flow: 20 gpd

Conditions of Certification:

Do not use where water is microbiologically unsafe or with water of unknown quality, except that systems certified for cyst reduction may be used on disinfected waters that may contain filterable cysts.

<sup>1</sup> Claims for arsenic reduction shall only be made on water supplies maintaining detectable residual free chlorine at the reverse osmosis (RO) system inlet. Water systems using an in-line chlorinator should provide a minimum of 1 minute chlorine contact time before the RO system.

<sup>2</sup>This system is acceptable for treatment of influent concentrations of no more than 27 mg/L nitrate and 3 mg/L nitrite in combination measured as N and is certified for nitrate/nitrite reduction only for water supplies with a pressure of 280 kPa (40 psig) or greater. A sampling and analysis test kit for nitrate is provided for checking the performance of this system. Frequent analysis is encouraged.

## Notes

---

## Notes

---



# Reverse Osmosis Appliance



The WQA Gold Seal assures that this product has been tested and validated by the Water Quality Association. This validation assures that all electrical components are UL or CSA listed and all components that are in contact with the treated water are FDA or NSF listed. The appliance conforms to NSF/ANSI 44 for softening performance, efficiency, Barium reduction, and Radium 226/228 reduction as verified and substantiated by test data. Barium/Radium reduction occurs as long as the appliance is softening the water. Test product water hardness every 12 months to check for proper functioning.

**HAGUE**  
**WATERMAX**

Hague Quality Water, Int'l  
4343 South Hamilton Road, Groveport, OH 43125  
Phone: 614-836-2115 • Fax: 614-836-9876